

R&S®SGU100A

SGMA Upconverter

Service Manual



1176.7732.02 – 03

This Service Manual provides servicing and maintenance procedures for the R&S® SGU100A.

© 2016 Rohde & Schwarz GmbH & Co. KG

Muehldorfstr. 15, 81671 Munich, Germany

Phone: +49 89 41 29 – 0

Fax: +49 89 41 29 12 164

E-mail: info@rohde-schwarz.com

Internet: <http://www.rohde-schwarz.com>

Subject to change – Data without tolerance limits is not binding.

R&S® is a registered trademark of Rohde & Schwarz GmbH & Co. KG.

Trade names are trademarks of the owners.

The following abbreviations are used throughout this manual:
R&S®SGU100A is abbreviated as R&S SGU100A.

Basic Safety Instructions

Always read through and comply with the following safety instructions!

All plants and locations of the Rohde & Schwarz group of companies make every effort to keep the safety standards of our products up to date and to offer our customers the highest possible degree of safety. Our products and the auxiliary equipment they require are designed, built and tested in accordance with the safety standards that apply in each case. Compliance with these standards is continuously monitored by our quality assurance system. The product described here has been designed, built and tested in accordance with the EC Certificate of Conformity and has left the manufacturer's plant in a condition fully complying with safety standards. To maintain this condition and to ensure safe operation, you must observe all instructions and warnings provided in this manual. If you have any questions regarding these safety instructions, the Rohde & Schwarz group of companies will be happy to answer them.

Furthermore, it is your responsibility to use the product in an appropriate manner. This product is designed for use solely in industrial and laboratory environments or, if expressly permitted, also in the field and must not be used in any way that may cause personal injury or property damage. You are responsible if the product is used for any purpose other than its designated purpose or in disregard of the manufacturer's instructions. The manufacturer shall assume no responsibility for such use of the product.

The product is used for its designated purpose if it is used in accordance with its product documentation and within its performance limits (see data sheet, documentation, the following safety instructions). Using the product requires technical skills and, in some cases, a basic knowledge of English. It is therefore essential that only skilled and specialized staff or thoroughly trained personnel with the required skills be allowed to use the product. If personal safety gear is required for using Rohde & Schwarz products, this will be indicated at the appropriate place in the product documentation. Keep the basic safety instructions and the product documentation in a safe place and pass them on to the subsequent users.

Observing the safety instructions will help prevent personal injury or damage of any kind caused by dangerous situations. Therefore, carefully read through and adhere to the following safety instructions before and when using the product. It is also absolutely essential to observe the additional safety instructions on personal safety, for example, that appear in relevant parts of the product documentation. In these safety instructions, the word "product" refers to all merchandise sold and distributed by the Rohde & Schwarz group of companies, including instruments, systems and all accessories. For product-specific information, see the data sheet and the product documentation.

Safety labels on products

The following safety labels are used on products to warn against risks and dangers.

Symbol	Meaning	Symbol	Meaning
	Notice, general danger location Observe product documentation		ON/OFF Power
	Caution when handling heavy equipment		Standby indication
	Danger of electric shock		Direct current (DC)

Basic Safety Instructions

Symbol	Meaning	Symbol	Meaning
	Caution ! Hot surface		Alternating current (AC)
	Protective conductor terminal To identify any terminal which is intended for connection to an external conductor for protection against electric shock in case of a fault, or the terminal of a protective earth		Direct/alternating current (DC/AC)
	Earth (Ground)		Class II Equipment to identify equipment meeting the safety requirements specified for Class II equipment (device protected by double or reinforced insulation)
	Frame or chassis Ground terminal		EU labeling for batteries and accumulators For additional information, see section "Waste disposal/Environmental protection", item 1.
	Be careful when handling electrostatic sensitive devices		EU labeling for separate collection of electrical and electronic devices For additional information, see section "Waste disposal/Environmental protection", item 2.
	Warning! Laser radiation For additional information, see section "Operation", item 7.		

Signal words and their meaning

The following signal words are used in the product documentation in order to warn the reader about risks and dangers.



Indicates a hazardous situation which, if not avoided, will result in death or serious injury.



Indicates a hazardous situation which, if not avoided, could result in death or serious injury.



Indicates a hazardous situation which, if not avoided, could result in minor or moderate injury.



Indicates information considered important, but not hazard-related, e.g. messages relating to property damage.
In the product documentation, the word ATTENTION is used synonymously.

These signal words are in accordance with the standard definition for civil applications in the European Economic Area. Definitions that deviate from the standard definition may also exist in other economic areas or military applications. It is therefore essential to make sure that the signal words described here are always used only in connection with the related product documentation and the related product. The use of signal words in connection with unrelated products or documentation can result in misinterpretation and in personal injury or material damage.

Basic Safety Instructions

Operating states and operating positions

The product may be operated only under the operating conditions and in the positions specified by the manufacturer, without the product's ventilation being obstructed. If the manufacturer's specifications are not observed, this can result in electric shock, fire and/or serious personal injury or death. Applicable local or national safety regulations and rules for the prevention of accidents must be observed in all work performed.

1. Unless otherwise specified, the following requirements apply to Rohde & Schwarz products: predefined operating position is always with the housing floor facing down, IP protection 2X, use only indoors, max. operating altitude 2000 m above sea level, max. transport altitude 4500 m above sea level. A tolerance of $\pm 10\%$ shall apply to the nominal voltage and $\pm 5\%$ to the nominal frequency, overvoltage category 2, pollution degree 2.
2. Do not place the product on surfaces, vehicles, cabinets or tables that for reasons of weight or stability are unsuitable for this purpose. Always follow the manufacturer's installation instructions when installing the product and fastening it to objects or structures (e.g. walls and shelves). An installation that is not carried out as described in the product documentation could result in personal injury or even death.
3. Do not place the product on heat-generating devices such as radiators or fan heaters. The ambient temperature must not exceed the maximum temperature specified in the product documentation or in the data sheet. Product overheating can cause electric shock, fire and/or serious personal injury or even death.

Electrical safety

If the information on electrical safety is not observed either at all or to the extent necessary, electric shock, fire and/or serious personal injury or death may occur.

1. Prior to switching on the product, always ensure that the nominal voltage setting on the product matches the nominal voltage of the mains-supply network. If a different voltage is to be set, the power fuse of the product may have to be changed accordingly.
2. In the case of products of safety class I with movable power cord and connector, operation is permitted only on sockets with a protective conductor contact and protective conductor.
3. Intentionally breaking the protective conductor either in the feed line or in the product itself is not permitted. Doing so can result in the danger of an electric shock from the product. If extension cords or connector strips are implemented, they must be checked on a regular basis to ensure that they are safe to use.
4. If there is no power switch for disconnecting the product from the mains, or if the power switch is not suitable for this purpose, use the plug of the connecting cable to disconnect the product from the mains. In such cases, always ensure that the power plug is easily reachable and accessible at all times. For example, if the power plug is the disconnecting device, the length of the connecting cable must not exceed 3 m. Functional or electronic switches are not suitable for providing disconnection from the AC supply network. If products without power switches are integrated into racks or systems, the disconnecting device must be provided at the system level.
5. Never use the product if the power cable is damaged. Check the power cables on a regular basis to ensure that they are in proper operating condition. By taking appropriate safety measures and carefully laying the power cable, ensure that the cable cannot be damaged and that no one can be hurt by, for example, tripping over the cable or suffering an electric shock.

Basic Safety Instructions

6. The product may be operated only from TN/TT supply networks fuse-protected with max. 16 A (higher fuse only after consulting with the Rohde & Schwarz group of companies).
7. Do not insert the plug into sockets that are dusty or dirty. Insert the plug firmly and all the way into the socket provided for this purpose. Otherwise, sparks that result in fire and/or injuries may occur.
8. Do not overload any sockets, extension cords or connector strips; doing so can cause fire or electric shocks.
9. For measurements in circuits with voltages $V_{rms} > 30$ V, suitable measures (e.g. appropriate measuring equipment, fuse protection, current limiting, electrical separation, insulation) should be taken to avoid any hazards.
10. Ensure that the connections with information technology equipment, e.g. PCs or other industrial computers, comply with the IEC 60950-1 / EN 60950-1 or IEC 61010-1 / EN 61010-1 standards that apply in each case.
11. Unless expressly permitted, never remove the cover or any part of the housing while the product is in operation. Doing so will expose circuits and components and can lead to injuries, fire or damage to the product.
12. If a product is to be permanently installed, the connection between the protective conductor terminal on site and the product's protective conductor must be made first before any other connection is made. The product may be installed and connected only by a licensed electrician.
13. For permanently installed equipment without built-in fuses, circuit breakers or similar protective devices, the supply circuit must be fuse-protected in such a way that anyone who has access to the product, as well as the product itself, is adequately protected from injury or damage.
14. Use suitable overvoltage protection to ensure that no overvoltage (such as that caused by a bolt of lightning) can reach the product. Otherwise, the person operating the product will be exposed to the danger of an electric shock.
15. Any object that is not designed to be placed in the openings of the housing must not be used for this purpose. Doing so can cause short circuits inside the product and/or electric shocks, fire or injuries.
16. Unless specified otherwise, products are not liquid-proof (see also section "Operating states and operating positions", item 1). Therefore, the equipment must be protected against penetration by liquids. If the necessary precautions are not taken, the user may suffer electric shock or the product itself may be damaged, which can also lead to personal injury.
17. Never use the product under conditions in which condensation has formed or can form in or on the product, e.g. if the product has been moved from a cold to a warm environment. Penetration by water increases the risk of electric shock.
18. Prior to cleaning the product, disconnect it completely from the power supply (e.g. AC supply network or battery). Use a soft, non-linting cloth to clean the product. Never use chemical cleaning agents such as alcohol, acetone or diluents for cellulose lacquers.

Operation

1. Operating the products requires special training and intense concentration. Make sure that persons who use the products are physically, mentally and emotionally fit enough to do so; otherwise, injuries or material damage may occur. It is the responsibility of the employer/operator to select suitable personnel for operating the products.

Basic Safety Instructions

2. Before you move or transport the product, read and observe the section titled "Transport".
3. As with all industrially manufactured goods, the use of substances that induce an allergic reaction (allergens) such as nickel cannot be generally excluded. If you develop an allergic reaction (such as a skin rash, frequent sneezing, red eyes or respiratory difficulties) when using a Rohde & Schwarz product, consult a physician immediately to determine the cause and to prevent health problems or stress.
4. Before you start processing the product mechanically and/or thermally, or before you take it apart, be sure to read and pay special attention to the section titled "Waste disposal/Environmental protection", item 1.
5. Depending on the function, certain products such as RF radio equipment can produce an elevated level of electromagnetic radiation. Considering that unborn babies require increased protection, pregnant women must be protected by appropriate measures. Persons with pacemakers may also be exposed to risks from electromagnetic radiation. The employer/operator must evaluate workplaces where there is a special risk of exposure to radiation and, if necessary, take measures to avert the potential danger.
6. Should a fire occur, the product may release hazardous substances (gases, fluids, etc.) that can cause health problems. Therefore, suitable measures must be taken, e.g. protective masks and protective clothing must be worn.
7. Laser products are given warning labels that are standardized according to their laser class. Lasers can cause biological harm due to the properties of their radiation and due to their extremely concentrated electromagnetic power. If a laser product (e.g. a CD/DVD drive) is integrated into a Rohde & Schwarz product, absolutely no other settings or functions may be used as described in the product documentation. The objective is to prevent personal injury (e.g. due to laser beams).
8. EMC classes (in line with EN 55011/CISPR 11, and analogously with EN 55022/CISPR 22, EN 55032/CISPR 32)
 - Class A equipment:
Equipment suitable for use in all environments except residential environments and environments that are directly connected to a low-voltage supply network that supplies residential buildings
Note: Class A equipment is intended for use in an industrial environment. This equipment may cause radio disturbances in residential environments, due to possible conducted as well as radiated disturbances. In this case, the operator may be required to take appropriate measures to eliminate these disturbances.
 - Class B equipment:
Equipment suitable for use in residential environments and environments that are directly connected to a low-voltage supply network that supplies residential buildings

Repair and service

1. The product may be opened only by authorized, specially trained personnel. Before any work is performed on the product or before the product is opened, it must be disconnected from the AC supply network. Otherwise, personnel will be exposed to the risk of an electric shock.

Basic Safety Instructions

- Adjustments, replacement of parts, maintenance and repair may be performed only by electrical experts authorized by Rohde & Schwarz. Only original parts may be used for replacing parts relevant to safety (e.g. power switches, power transformers, fuses). A safety test must always be performed after parts relevant to safety have been replaced (visual inspection, protective conductor test, insulation resistance measurement, leakage current measurement, functional test). This helps ensure the continued safety of the product.

Batteries and rechargeable batteries/cells

If the information regarding batteries and rechargeable batteries/cells is not observed either at all or to the extent necessary, product users may be exposed to the risk of explosions, fire and/or serious personal injury, and, in some cases, death. Batteries and rechargeable batteries with alkaline electrolytes (e.g. lithium cells) must be handled in accordance with the EN 62133 standard.

- Cells must not be taken apart or crushed.
- Cells or batteries must not be exposed to heat or fire. Storage in direct sunlight must be avoided. Keep cells and batteries clean and dry. Clean soiled connectors using a dry, clean cloth.
- Cells or batteries must not be short-circuited. Cells or batteries must not be stored in a box or in a drawer where they can short-circuit each other, or where they can be short-circuited by other conductive materials. Cells and batteries must not be removed from their original packaging until they are ready to be used.
- Cells and batteries must not be exposed to any mechanical shocks that are stronger than permitted.
- If a cell develops a leak, the fluid must not be allowed to come into contact with the skin or eyes. If contact occurs, wash the affected area with plenty of water and seek medical aid.
- Improperly replacing or charging cells or batteries that contain alkaline electrolytes (e.g. lithium cells) can cause explosions. Replace cells or batteries only with the matching Rohde & Schwarz type (see parts list) in order to ensure the safety of the product.
- Cells and batteries must be recycled and kept separate from residual waste. Rechargeable batteries and normal batteries that contain lead, mercury or cadmium are hazardous waste. Observe the national regulations regarding waste disposal and recycling.

Transport

- The product may be very heavy. Therefore, the product must be handled with care. In some cases, the user may require a suitable means of lifting or moving the product (e.g. with a lift-truck) to avoid back or other physical injuries.
- Handles on the products are designed exclusively to enable personnel to transport the product. It is therefore not permissible to use handles to fasten the product to or on transport equipment such as cranes, fork lifts, wagons, etc. The user is responsible for securely fastening the products to or on the means of transport or lifting. Observe the safety regulations of the manufacturer of the means of transport or lifting. Noncompliance can result in personal injury or material damage.
- If you use the product in a vehicle, it is the sole responsibility of the driver to drive the vehicle safely and properly. The manufacturer assumes no responsibility for accidents or collisions. Never use the product in a moving vehicle if doing so could distract the driver of the vehicle. Adequately secure the product in the vehicle to prevent injuries or other damage in the event of an accident.

Instrucciones de seguridad elementales

Waste disposal/Environmental protection

1. Specially marked equipment has a battery or accumulator that must not be disposed of with unsorted municipal waste, but must be collected separately. It may only be disposed of at a suitable collection point or via a Rohde & Schwarz customer service center.
2. Waste electrical and electronic equipment must not be disposed of with unsorted municipal waste, but must be collected separately.
Rohde & Schwarz GmbH & Co. KG has developed a disposal concept and takes full responsibility for take-back obligations and disposal obligations for manufacturers within the EU. Contact your Rohde & Schwarz customer service center for environmentally responsible disposal of the product.
3. If products or their components are mechanically and/or thermally processed in a manner that goes beyond their intended use, hazardous substances (heavy-metal dust such as lead, beryllium, nickel) may be released. For this reason, the product may only be disassembled by specially trained personnel. Improper disassembly may be hazardous to your health. National waste disposal regulations must be observed.
4. If handling the product releases hazardous substances or fuels that must be disposed of in a special way, e.g. coolants or engine oils that must be replenished regularly, the safety instructions of the manufacturer of the hazardous substances or fuels and the applicable regional waste disposal regulations must be observed. Also observe the relevant safety instructions in the product documentation. The improper disposal of hazardous substances or fuels can cause health problems and lead to environmental damage.

For additional information about environmental protection, visit the Rohde & Schwarz website.

Instrucciones de seguridad elementales

¡Es imprescindible leer y cumplir las siguientes instrucciones e informaciones de seguridad!

El principio del grupo de empresas Rohde & Schwarz consiste en tener nuestros productos siempre al día con los estándares de seguridad y de ofrecer a nuestros clientes el máximo grado de seguridad. Nuestros productos y todos los equipos adicionales son siempre fabricados y examinados según las normas de seguridad vigentes. Nuestro sistema de garantía de calidad controla constantemente que sean cumplidas estas normas. El presente producto ha sido fabricado y examinado según el certificado de conformidad de la UE y ha salido de nuestra planta en estado impecable según los estándares técnicos de seguridad. Para poder preservar este estado y garantizar un funcionamiento libre de peligros, el usuario deberá atenerse a todas las indicaciones, informaciones de seguridad y notas de alerta. El grupo de empresas Rohde & Schwarz está siempre a su disposición en caso de que tengan preguntas referentes a estas informaciones de seguridad.

Además queda en la responsabilidad del usuario utilizar el producto en la forma debida. Este producto está destinado exclusivamente al uso en la industria y el laboratorio o, si ha sido expresamente autorizado, para aplicaciones de campo y de ninguna manera deberá ser utilizado de modo que alguna persona/cosa pueda sufrir daño. El uso del producto fuera de sus fines definidos o sin tener en cuenta las instrucciones del fabricante queda en la responsabilidad del usuario. El fabricante no se hace en ninguna forma responsable de consecuencias a causa del mal uso del producto.















Instrucciones de seguridad elementales

Se parte del uso correcto del producto para los fines definidos si el producto es utilizado conforme a las indicaciones de la correspondiente documentación del producto y dentro del margen de rendimiento definido (ver hoja de datos, documentación, informaciones de seguridad que siguen). El uso del producto hace necesarios conocimientos técnicos y ciertos conocimientos del idioma inglés. Por eso se debe tener en cuenta que el producto solo pueda ser operado por personal especializado o personas instruidas en profundidad con las capacidades correspondientes. Si fuera necesaria indumentaria de seguridad para el uso de productos de Rohde & Schwarz, encontraría la información debida en la documentación del producto en el capítulo correspondiente. Guarde bien las informaciones de seguridad elementales, así como la documentación del producto, y entréguelas a usuarios posteriores.

Tener en cuenta las informaciones de seguridad sirve para evitar en lo posible lesiones o daños por peligros de toda clase. Por eso es imprescindible leer detalladamente y comprender por completo las siguientes informaciones de seguridad antes de usar el producto, y respetarlas durante el uso del producto. Deberán tenerse en cuenta todas las demás informaciones de seguridad, como p. ej. las referentes a la protección de personas, que encontrarán en el capítulo correspondiente de la documentación del producto y que también son de obligado cumplimiento. En las presentes informaciones de seguridad se recogen todos los objetos que distribuye el grupo de empresas Rohde & Schwarz bajo la denominación de "producto", entre ellos también aparatos, instalaciones así como toda clase de accesorios. Los datos específicos del producto figuran en la hoja de datos y en la documentación del producto.

Señalización de seguridad de los productos

Las siguientes señales de seguridad se utilizan en los productos para advertir sobre riesgos y peligros.

Símbolo	Significado	Símbolo	Significado
	Aviso: punto de peligro general Observar la documentación del producto		Tensión de alimentación de PUESTA EN MARCHA / PARADA
	Atención en el manejo de dispositivos de peso elevado		Indicación de estado de espera (standby)
	Peligro de choque eléctrico		Corriente continua (DC)
	Advertencia: superficie caliente		Corriente alterna (AC)
	Conexión a conductor de protección		Corriente continua / Corriente alterna (DC/AC)
	Conexión a tierra		El aparato está protegido en su totalidad por un aislamiento doble (reforzado)
	Conexión a masa		Distintivo de la UE para baterías y acumuladores Más información en la sección "Eliminación/protección del medio ambiente", punto 1.

Instrucciones de seguridad elementales

Símbolo	Significado	Símbolo	Significado
	Aviso: Cuidado en el manejo de dispositivos sensibles a la electrostática (ESD)		Distintivo de la UE para la eliminación por separado de dispositivos eléctricos y electrónicos Más información en la sección "Eliminación/protección del medio ambiente", punto 2.
	Advertencia: rayo láser Más información en la sección "Funcionamiento", punto 7.		

Palabras de señal y su significado

En la documentación del producto se utilizan las siguientes palabras de señal con el fin de advertir contra riesgos y peligros.



Indica una situación de peligro que, si no se evita, causa lesiones graves o incluso la muerte.



Indica una situación de peligro que, si no se evita, puede causar lesiones graves o incluso la muerte.



Indica una situación de peligro que, si no se evita, puede causar lesiones leves o moderadas.



Indica información que se considera importante, pero no en relación con situaciones de peligro; p. ej., avisos sobre posibles daños materiales.

En la documentación del producto se emplea de forma sinónima el término CUIDADO.

Las palabras de señal corresponden a la definición habitual para aplicaciones civiles en el área económica europea. Pueden existir definiciones diferentes a esta definición en otras áreas económicas o en aplicaciones militares. Por eso se deberá tener en cuenta que las palabras de señal aquí descritas sean utilizadas siempre solamente en combinación con la correspondiente documentación del producto y solamente en combinación con el producto correspondiente. La utilización de las palabras de señal en combinación con productos o documentaciones que no les correspondan puede llevar a interpretaciones equivocadas y tener por consecuencia daños en personas u objetos.

Estados operativos y posiciones de funcionamiento

El producto solamente debe ser utilizado según lo indicado por el fabricante respecto a los estados operativos y posiciones de funcionamiento sin que se obstruya la ventilación. Si no se siguen las indicaciones del fabricante, pueden producirse choques eléctricos, incendios y/o lesiones graves con posible consecuencia de muerte. En todos los trabajos deberán ser tenidas en cuenta las normas nacionales y locales de seguridad del trabajo y de prevención de accidentes.

Instrucciones de seguridad elementales

1. Si no se convino de otra manera, es para los productos Rohde & Schwarz válido lo que sigue: como posición de funcionamiento se define por principio la posición con el suelo de la caja para abajo, modo de protección IP 2X, uso solamente en estancias interiores, utilización hasta 2000 m sobre el nivel del mar, transporte hasta 4500 m sobre el nivel del mar. Se aplicará una tolerancia de $\pm 10\%$ sobre el voltaje nominal y de $\pm 5\%$ sobre la frecuencia nominal. Categoría de sobrecarga eléctrica 2, índice de suciedad 2.
2. No sitúe el producto encima de superficies, vehículos, estantes o mesas, que por sus características de peso o de estabilidad no sean aptos para él. Siga siempre las instrucciones de instalación del fabricante cuando instale y asegure el producto en objetos o estructuras (p. ej. paredes y estantes). Si se realiza la instalación de modo distinto al indicado en la documentación del producto, se pueden causar lesiones o, en determinadas circunstancias, incluso la muerte.
3. No ponga el producto sobre aparatos que generen calor (p. ej. radiadores o calefactores). La temperatura ambiente no debe superar la temperatura máxima especificada en la documentación del producto o en la hoja de datos. En caso de sobrecalentamiento del producto, pueden producirse choques eléctricos, incendios y/o lesiones graves con posible consecuencia de muerte.

Seguridad eléctrica

Si no se siguen (o se siguen de modo insuficiente) las indicaciones del fabricante en cuanto a seguridad eléctrica, pueden producirse choques eléctricos, incendios y/o lesiones graves con posible consecuencia de muerte.

1. Antes de la puesta en marcha del producto se deberá comprobar siempre que la tensión preseleccionada en el producto coincida con la de la red de alimentación eléctrica. Si es necesario modificar el ajuste de tensión, también se deberán cambiar en caso dado los fusibles correspondientes del producto.
2. Los productos de la clase de protección I con alimentación móvil y enchufe individual solamente podrán enchufarse a tomas de corriente con contacto de seguridad y con conductor de protección conectado.
3. Queda prohibida la interrupción intencionada del conductor de protección, tanto en la toma de corriente como en el mismo producto. La interrupción puede tener como consecuencia el riesgo de que el producto sea fuente de choques eléctricos. Si se utilizan cables alargadores o regletas de enchufe, deberá garantizarse la realización de un examen regular de los mismos en cuanto a su estado técnico de seguridad.
4. Si el producto no está equipado con un interruptor para desconectarlo de la red, o bien si el interruptor existente no resulta apropiado para la desconexión de la red, el enchufe del cable de conexión se deberá considerar como un dispositivo de desconexión. El dispositivo de desconexión se debe poder alcanzar fácilmente y debe estar siempre bien accesible. Si, p. ej., el enchufe de conexión a la red es el dispositivo de desconexión, la longitud del cable de conexión no debe superar 3 m). Los interruptores selectores o electrónicos no son aptos para el corte de la red eléctrica. Si se integran productos sin interruptor en bastidores o instalaciones, se deberá colocar el interruptor en el nivel de la instalación.
5. No utilice nunca el producto si está dañado el cable de conexión a red. Compruebe regularmente el correcto estado de los cables de conexión a red. Asegúrese, mediante las medidas de protección y de instalación adecuadas, de que el cable de conexión a red no pueda ser dañado o de que nadie pueda ser dañado por él, p. ej. al tropezar o por un choque eléctrico.

Instrucciones de seguridad elementales

6. Solamente está permitido el funcionamiento en redes de alimentación TN/TT aseguradas con fusibles de 16 A como máximo (utilización de fusibles de mayor amperaje solo previa consulta con el grupo de empresas Rohde & Schwarz).
7. Nunca conecte el enchufe en tomas de corriente sucias o llenas de polvo. Introduzca el enchufe por completo y fuertemente en la toma de corriente. La no observación de estas medidas puede provocar chispas, fuego y/o lesiones.
8. No sobrecargue las tomas de corriente, los cables alargadores o las regletas de enchufe ya que esto podría causar fuego o choques eléctricos.
9. En las mediciones en circuitos de corriente con una tensión $U_{\text{eff}} > 30 \text{ V}$ se deberán tomar las medidas apropiadas para impedir cualquier peligro (p. ej. medios de medición adecuados, seguros, limitación de tensión, corte protector, aislamiento etc.).
10. Para la conexión con dispositivos informáticos como un PC o un ordenador industrial, debe comprobarse que éstos cumplan los estándares IEC60950-1/EN60950-1 o IEC61010-1/EN 61010-1 válidos en cada caso.
11. A menos que esté permitido expresamente, no retire nunca la tapa ni componentes de la carcasa mientras el producto esté en servicio. Esto pone a descubierto los cables y componentes eléctricos y puede causar lesiones, fuego o daños en el producto.
12. Si un producto se instala en un lugar fijo, se deberá primero conectar el conductor de protección fijo con el conductor de protección del producto antes de hacer cualquier otra conexión. La instalación y la conexión deberán ser efectuadas por un electricista especializado.
13. En el caso de dispositivos fijos que no estén provistos de fusibles, interruptor automático ni otros mecanismos de seguridad similares, el circuito de alimentación debe estar protegido de modo que todas las personas que puedan acceder al producto, así como el producto mismo, estén a salvo de posibles daños.
14. Todo producto debe estar protegido contra sobretensión (debida p. ej. a una caída del rayo) mediante los correspondientes sistemas de protección. Si no, el personal que lo utilice quedará expuesto al peligro de choque eléctrico.
15. No debe introducirse en los orificios de la caja del aparato ningún objeto que no esté destinado a ello. Esto puede producir cortocircuitos en el producto y/o puede causar choques eléctricos, fuego o lesiones.
16. Salvo indicación contraria, los productos no están impermeabilizados (ver también el capítulo "Estados operativos y posiciones de funcionamiento", punto 1). Por eso es necesario tomar las medidas necesarias para evitar la entrada de líquidos. En caso contrario, existe peligro de choque eléctrico para el usuario o de daños en el producto, que también pueden redundar en peligro para las personas.
17. No utilice el producto en condiciones en las que pueda producirse o ya se hayan producido condensaciones sobre el producto o en el interior de éste, como p. ej. al desplazarlo de un lugar frío a otro caliente. La entrada de agua aumenta el riesgo de choque eléctrico.
18. Antes de la limpieza, desconecte por completo el producto de la alimentación de tensión (p. ej. red de alimentación o batería). Realice la limpieza de los aparatos con un paño suave, que no se deshilache. No utilice bajo ningún concepto productos de limpieza químicos como alcohol, acetona o diluyentes para lacas nitrocelulósicas.

Instrucciones de seguridad elementales

Funcionamiento

1. El uso del producto requiere instrucciones especiales y una alta concentración durante el manejo. Debe asegurarse que las personas que manejen el producto estén a la altura de los requerimientos necesarios en cuanto a aptitudes físicas, psíquicas y emocionales, ya que de otra manera no se pueden excluir lesiones o daños de objetos. El empresario u operador es responsable de seleccionar el personal usuario apto para el manejo del producto.
2. Antes de desplazar o transportar el producto, lea y tenga en cuenta el capítulo "Transporte".
3. Como con todo producto de fabricación industrial no puede quedar excluida en general la posibilidad de que se produzcan alergias provocadas por algunos materiales empleados —los llamados alérgenos (p. ej. el níquel)—. Si durante el manejo de productos Rohde & Schwarz se producen reacciones alérgicas, como p. ej. irritaciones cutáneas, estornudos continuos, enrojecimiento de la conjuntiva o dificultades respiratorias, debe avisarse inmediatamente a un médico para investigar las causas y evitar cualquier molestia o daño a la salud.
4. Antes de la manipulación mecánica y/o térmica o el desmontaje del producto, debe tenerse en cuenta imprescindiblemente el capítulo "Eliminación/protección del medio ambiente", punto 1.
5. Ciertos productos, como p. ej. las instalaciones de radiocomunicación RF, pueden a causa de su función natural, emitir una radiación electromagnética aumentada. Deben tomarse todas las medidas necesarias para la protección de las mujeres embarazadas. También las personas con marcapasos pueden correr peligro a causa de la radiación electromagnética. El empresario/operador tiene la obligación de evaluar y señalar las áreas de trabajo en las que exista un riesgo elevado de exposición a radiaciones.
6. Tenga en cuenta que en caso de incendio pueden desprenderse del producto sustancias tóxicas (gases, líquidos etc.) que pueden generar daños a la salud. Por eso, en caso de incendio deben usarse medidas adecuadas, como p. ej. máscaras antigás e indumentaria de protección.
7. Los productos con láser están provistos de indicaciones de advertencia normalizadas en función de la clase de láser del que se trate. Los rayos láser pueden provocar daños de tipo biológico a causa de las propiedades de su radiación y debido a su concentración extrema de potencia electromagnética. En caso de que un producto Rohde & Schwarz contenga un producto láser (p. ej. un lector de CD/DVD), no debe usarse ninguna otra configuración o función aparte de las descritas en la documentación del producto, a fin de evitar lesiones (p. ej. debidas a irradiación láser).
8. Clases de compatibilidad electromagnética (conforme a EN 55011 / CISPR 11; y en analogía con EN 55022 / CISPR 22, EN 55032 / CISPR 32)
 - Aparato de clase A:
Aparato adecuado para su uso en todos los entornos excepto en los residenciales y en aquellos conectados directamente a una red de distribución de baja tensión que suministra corriente a edificios residenciales.
Nota: Los aparatos de clase A están destinados al uso en entornos industriales. Estos aparatos pueden causar perturbaciones radioeléctricas en entornos residenciales debido a posibles perturbaciones guiadas o radiadas. En este caso, se le podrá solicitar al operador que tome las medidas adecuadas para eliminar estas perturbaciones.
 - Aparato de clase B:
Aparato adecuado para su uso en entornos residenciales, así como en aquellos conectados directamente a una red de distribución de baja tensión que suministra corriente a edificios residenciales.

Instrucciones de seguridad elementales

Reparación y mantenimiento

1. El producto solamente debe ser abierto por personal especializado con autorización para ello. Antes de manipular el producto o abrirlo, es obligatorio desconectarlo de la tensión de alimentación, para evitar toda posibilidad de choque eléctrico.
2. El ajuste, el cambio de partes, el mantenimiento y la reparación deberán ser efectuadas solamente por electricistas autorizados por Rohde & Schwarz. Si se reponen partes con importancia para los aspectos de seguridad (p. ej. el enchufe, los transformadores o los fusibles), solamente podrán ser sustituidos por partes originales. Después de cada cambio de partes relevantes para la seguridad deberá realizarse un control de seguridad (control a primera vista, control del conductor de protección, medición de resistencia de aislamiento, medición de la corriente de fuga, control de funcionamiento). Con esto queda garantizada la seguridad del producto.

Baterías y acumuladores o celdas

Si no se siguen (o se siguen de modo insuficiente) las indicaciones en cuanto a las baterías y acumuladores o celdas, pueden producirse explosiones, incendios y/o lesiones graves con posible consecuencia de muerte. El manejo de baterías y acumuladores con electrolitos alcalinos (p. ej. celdas de litio) debe seguir el estándar EN 62133.

1. No deben desmontarse, abrirse ni triturarse las celdas.
2. Las celdas o baterías no deben someterse a calor ni fuego. Debe evitarse el almacenamiento a la luz directa del sol. Las celdas y baterías deben mantenerse limpias y secas. Limpiar las conexiones sucias con un paño seco y limpio.
3. Las celdas o baterías no deben cortocircuitarse. Es peligroso almacenar las celdas o baterías en estuches o cajones en cuyo interior puedan cortocircuitarse por contacto recíproco o por contacto con otros materiales conductores. No deben extraerse las celdas o baterías de sus embalajes originales hasta el momento en que vayan a utilizarse.
4. Las celdas o baterías no deben someterse a impactos mecánicos fuertes indebidos.
5. En caso de falta de estanqueidad de una celda, el líquido vertido no debe entrar en contacto con la piel ni los ojos. Si se produce contacto, lavar con agua abundante la zona afectada y avisar a un médico.
6. En caso de cambio o recarga inadecuados, las celdas o baterías que contienen electrolitos alcalinos (p. ej. las celdas de litio) pueden explotar. Para garantizar la seguridad del producto, las celdas o baterías solo deben ser sustituidas por el tipo Rohde & Schwarz correspondiente (ver lista de recambios).
7. Las baterías y celdas deben reciclarse y no deben tirarse a la basura doméstica. Las baterías o acumuladores que contienen plomo, mercurio o cadmio deben tratarse como residuos especiales. Respete en esta relación las normas nacionales de eliminación y reciclaje.

Transporte

1. El producto puede tener un peso elevado. Por eso es necesario desplazarlo o transportarlo con precaución y, si es necesario, usando un sistema de elevación adecuado (p. ej. una carretilla elevadora), a fin de evitar lesiones en la espalda u otros daños personales.

Instrucciones de seguridad elementales

2. Las asas instaladas en los productos sirven solamente de ayuda para el transporte del producto por personas. Por eso no está permitido utilizar las asas para la sujeción en o sobre medios de transporte como p. ej. grúas, carretillas elevadoras de horquilla, carros etc. Es responsabilidad suya fijar los productos de manera segura a los medios de transporte o elevación. Para evitar daños personales o daños en el producto, siga las instrucciones de seguridad del fabricante del medio de transporte o elevación utilizado.
3. Si se utiliza el producto dentro de un vehículo, recae de manera exclusiva en el conductor la responsabilidad de conducir el vehículo de manera segura y adecuada. El fabricante no asumirá ninguna responsabilidad por accidentes o colisiones. No utilice nunca el producto dentro de un vehículo en movimiento si esto pudiera distraer al conductor. Asegure el producto dentro del vehículo debidamente para evitar, en caso de un accidente, lesiones u otra clase de daños.

Eliminación/protección del medio ambiente

1. Los dispositivos marcados contienen una batería o un acumulador que no se debe desechar con los residuos domésticos sin clasificar, sino que debe ser recogido por separado. La eliminación se debe efectuar exclusivamente a través de un punto de recogida apropiado o del servicio de atención al cliente de Rohde & Schwarz.
2. Los dispositivos eléctricos usados no se deben desechar con los residuos domésticos sin clasificar, sino que deben ser recogidos por separado.
Rohde & Schwarz GmbH & Co.KG ha elaborado un concepto de eliminación de residuos y asume plenamente los deberes de recogida y eliminación para los fabricantes dentro de la UE. Para desechar el producto de manera respetuosa con el medio ambiente, dirijase a su servicio de atención al cliente de Rohde & Schwarz.
3. Si se trabaja de manera mecánica y/o térmica cualquier producto o componente más allá del funcionamiento previsto, pueden liberarse sustancias peligrosas (polvos con contenido de metales pesados como p. ej. plomo, berilio o níquel). Por eso el producto solo debe ser desmontado por personal especializado con formación adecuada. Un desmontaje inadecuado puede ocasionar daños para la salud. Se deben tener en cuenta las directivas nacionales referentes a la eliminación de residuos.
4. En caso de que durante el trato del producto se formen sustancias peligrosas o combustibles que deban tratarse como residuos especiales (p. ej. refrigerantes o aceites de motor con intervalos de cambio definidos), deben tenerse en cuenta las indicaciones de seguridad del fabricante de dichas sustancias y las normas regionales de eliminación de residuos. Tenga en cuenta también en caso necesario las indicaciones de seguridad especiales contenidas en la documentación del producto. La eliminación incorrecta de sustancias peligrosas o combustibles puede causar daños a la salud o daños al medio ambiente.

Se puede encontrar más información sobre la protección del medio ambiente en la página web de Rohde & Schwarz.

Instructions for Electrostatic Discharge Protection

NOTICE

Risk of damaging electronic components

To avoid damage of electronic components, the operational site must be protected against electrostatic discharge (ESD).

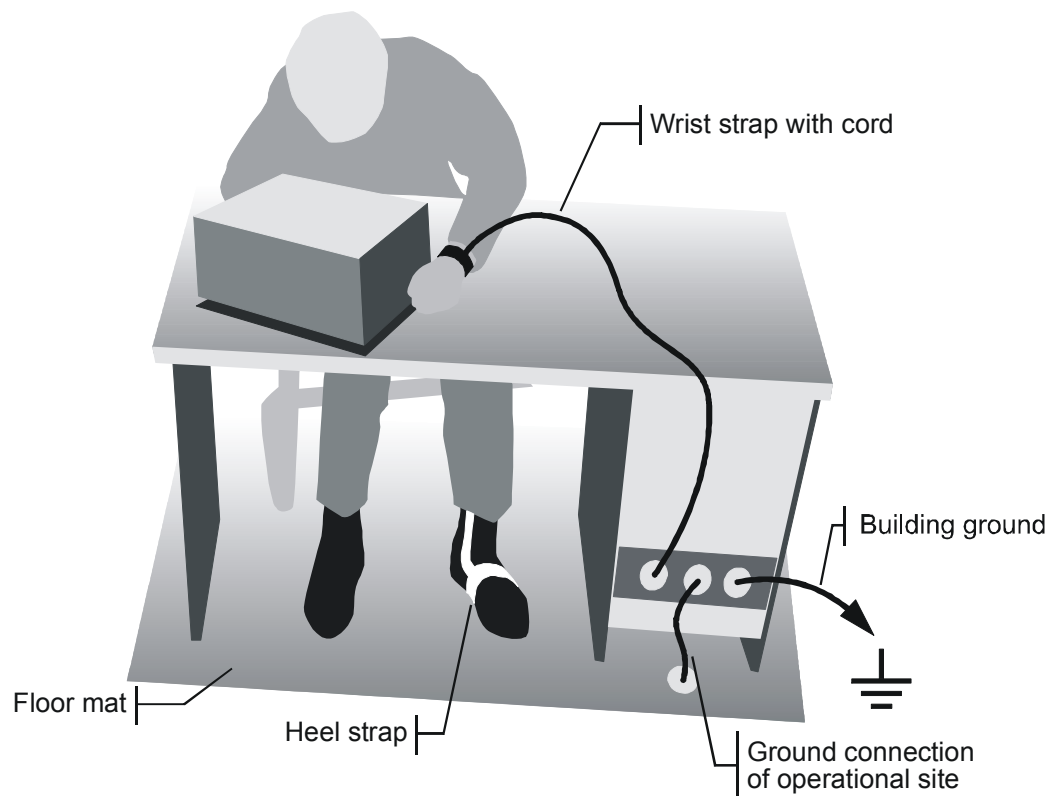

The following two methods of ESD protection may be used together or separately:

- Wrist strap with cord to ground connection
 - Conductive floor mat and heel strap combination
-

Instrucciones para la protección contra descargas electrostáticas

AVISO

Riesgo de avería de los componentes electrónicos

Para evitar averías en los componentes electrónicos, el área de trabajo tiene que estar protegido contra descargas electrostáticas ESD (electrostatic discharge).

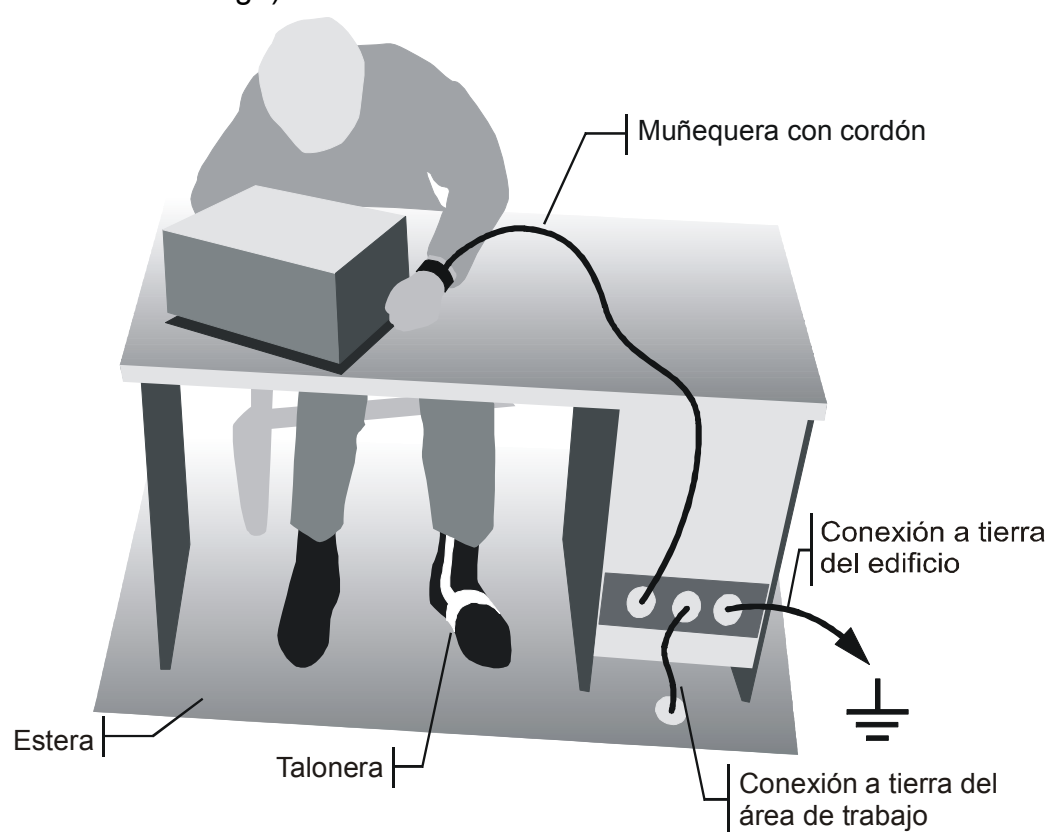

Los siguientes dos métodos de protección ESD pueden ser usados juntos o separados:

- Muñequera con cordón para conexión a tierra
- Combinación de estera antiestática y talonera

Procedure in Case of Service and Ordering of Spare Parts

This section contains information on shipping an instrument to your service center and ordering spare parts.

Please contact your local Rohde & Schwarz service center if you need service or repair work of your equipment or to order spare parts. You can find the current address of your representative on our homepage www.rohde-schwarz.com.

Shipping the Instrument

We require the following information in order to answer your inquiry fast and correctly and to determine whether the warranty is still valid for your instrument:

- Instrument model
- Serial number
- Firmware version
- Must the instrument be returned with this firmware?
- Detailed error description in case of repair
- Indication of desired calibration
- Contact person for possible questions

In some countries, an RMA process is available for the return shipment of the instrument. For details, contact your local representative.

When shipping the instrument, be careful to provide for sufficient mechanical and antistatic protection.

- Use the original packaging for transporting or shipping the instrument. The protective caps for the front and rear prevent damage to the operating elements and the connectors.
- If you do not use the original packaging, provide for sufficient padding to prevent the instrument from slipping inside the box. Wrap antistatic packing foil around the instrument to protect it from electrostatic charging.

Rohde & Schwarz offers repair and calibrations of the test systems it produces. The calibration documentation fulfills ISO 17025 requirements.

Shipping Defective Modules

Also when shipping a module, be careful to provide for sufficient mechanical and antistatic protection.

- Ship the module in a sturdy, padded box.
- Wrap the module in antistatic foil.

If the packaging is only antistatic but not conductive, additional conductive packaging is required. The additional packaging is not required if the tightly fitting packaging is conductive.

Exception:

If the module contains a battery, the tightly fitting packaging must always consist of antistatic, non-chargeable material to protect the battery from being discharged.

Ordering Spare Parts

To deliver spare parts promptly and correctly, we need the following information:

- Stock number (see list of spare parts in chapter "Documents")
- Designation
- Component number according to list of spare parts
- Number of pieces
- Instrument type for which the spare part is needed
- Instrument stock number
- Instrument serial number
- Contact person for possible questions

Refurbished Modules

Refurbished modules are an economical alternative to original modules. Bear in mind that refurbished modules are not new, but repaired and fully tested parts. They may have traces from use, but they are electrically and mechanically equivalent to new modules.

Your Rohde & Schwarz representative will be happy to inform you about which modules are available as refurbished modules.

Taking Back Defective Replaced Modules

Defective modules of the replacement program which cannot be repaired are taken back within three months following delivery. A repurchasing value is credited.

Excluded are parts which cannot be repaired, e.g. printed boards that are burnt, broken or damaged by attempts to repair them, incomplete modules, and parts with severe mechanical damage.

Please return the defective replacement modules, together with the accompanying document for returned merchandise, which you received with the spare module. We need the following information:

- Stock number, serial number and designation of the removed part
- Detailed error description
- Stock number, serial number and type of instrument from which the module was removed
- Date of removal
- Name of the engineer/technician who replaced the module
- R&S ordering number
- Service reference number (if available)

Table of Contents

1	Performance Test	7
1.1	Test Equipment	7
1.2	Test Assemblies	9
1.2.1	Test Assembly for gen. spectrum and modulation measurements	9
1.2.2	Test Assembly for Output Impedance (VSWR)	10
1.2.3	Test Assembly for Setting Time	11
1.2.4	Test Assembly for Pulse Modulation	11
1.2.5	Test Assembly for Pulse Video Crosstalk.....	12
1.3	Preparation, Recommended Test Frequencies and Levels	13
1.4	Test Procedures	15
1.4.1	Frequency Setting Time	15
1.4.2	Spectral Purity	19
1.4.2.1	Harmonics	19
1.4.2.2	Subharmonics	20
1.4.2.3	Non systematic nonharmonics	20
1.4.2.4	Wideband Noise	21
1.4.2.5	Residual AM	23
1.4.3	Level Data	25
1.4.3.1	Level Uncertainty	25
1.4.3.2	Output Impedance.....	27
1.4.3.3	Setting Time	28
1.4.4	Pulse Modulation.....	30
1.4.4.1	ON/OFF Ratio	30
1.4.4.2	Rise/ Fall Time and Pulse Overshoot.....	31
1.4.4.3	Video Crosstalk	32
1.4.5	I/Q modulation.....	33
1.4.5.1	Input Impedance (VSWR)	33
1.4.5.2	Dynamic Error Vector	34
1.4.5.3	Residual Carrier and Leakage	35
1.4.5.4	I/Q Imbalance.....	36
1.4.6	Phase Coherence Levels	37

1.4.7	PCI Express Interface	38
2	Adjustment	39
2.1	Procedures after Module Replacement	39
2.1.1	Restore Ethernet MAC Adress	40
2.2	Adding Hardware Options	41
2.3	Internal Adjustments	42
2.4	External Adjustments Requiring Measurement Equipment	42
2.5	Internal Self Test	42
2.5.1	Troubleshooting with Signal Connection Test	43
3	Repair	44
3.1	Functional Description	45
3.1.1	Power Supply Module	45
3.1.2	Controller Board	45
3.1.2.1	Switching regulators	45
3.1.2.2	Controller	45
3.1.2.3	FPGA45	
3.1.2.4	Diagnostic Multiplexer	45
3.1.2.5	EEPROM	45
3.1.2.6	Temperature sensor	46
3.1.3	Upconverter Mainboard	46
3.1.3.1	Block diagram	46
3.1.3.2	Implemented functions	46
3.1.3.3	Frequency doubler	47
3.1.3.4	Vector modulator	47
3.1.3.5	Automatic Level control	47
3.1.3.6	Fan Controller	47
3.1.3.7	Supply voltage control and filtering	47
3.1.4	Doubler Board	48
3.1.4.1	Doubler Board architecture	48
3.1.4.2	Doubler Board diagram	48
3.1.5	Step Attenuator	49
3.1.5.1	Step Attenuator architecture	49
3.1.5.2	Step Attenuator diagram	49

3.2	Troubleshooting	50
3.2.1	Measuring Equipment and Accessories	51
3.2.2	Switch-On Problems	51
3.2.2.1	Test Points on Controller Board	53
3.2.3	Keyboard and LED Test	54
3.2.4	USB Cable Test	55
3.2.5	Connecting the SGU100A to the SGS100A LO Source	55
3.2.6	Troubleshooting with Signal Connection Test	56
3.2.7	Troubleshooting with Internal Selftest	57
3.2.8	Troubleshooting with Internal Adjustments	58
3.2.9	Instrument Faults	59
3.2.9.1	Fuses63	
3.2.10	Troubleshooting – Upconverter Mainboard	64
3.2.10.1	Internal Adjustment “Adjust All”	64
3.2.10.2	Input and Output Signals	65
3.2.10.3	Error Messages Concerning the Upconverter Mainboard	67
3.2.10.4	Warnings Concerning the Upconverter Mainboard	67
3.2.11	Troubleshooting – Step Attenuator	67
3.2.11.1	Supply Voltages	67
3.2.12	Troubleshooting – Doubler Board opt. R&S SGU-B140/-B140V	68
3.2.12.1	Supply Voltages	68
3.2.13	Troubleshooting with Signal Connection Test	69
3.2.13.1	Input and Output Signals	70
3.3	Module Replacement and Upgrade	71
3.3.1	Required Tools	71
3.3.2	Module Overview and Information about Part Lists	72
3.3.3	After Replacing an Assembly	73
3.3.4	Removing the Case	73
3.3.5	Installing the Case	74
3.3.6	Replacing the EMC Panel	75
3.3.6.1	Removing the EMC Panel	75
3.3.6.2	Installing the EMC Panel	75
3.3.7	Replacing the Power Supply (A50)	76

3.3.7.1	Removing the Power Supply	76
3.3.7.2	Installing the Power Supply (A50)	77
3.3.8	Replacing the Front Unit	78
3.3.8.1	Removing the Front Unit	78
3.3.8.2	Installing the Front Unit	79
3.3.9	Replacing the Frontmoduleboard A300	80
3.3.9.1	Removing the Frontmoduleboard and the Rubber Keypad	80
3.3.9.2	Installing the Frontmoduleboard and Rubber Keypad	81
3.3.10	Replacing the RF-Upconverter (A200).....	82
3.3.10.1	Removing the RF-Upconverter	82
3.3.10.2	Installing the RF-Upconverter (A200)	85
3.3.11	Replacing the Controller Board A100.....	88
3.3.11.1	Removing the Controller Board.....	88
3.3.11.2	Installing the Controller board (A100)	88
3.3.11.3	Replacing the SIM Card	89
3.3.12	Replacing the Fan E1.....	90
3.3.13	Replacing the IQ-Upcon 40 Module - R&S SGU-B140/-B140V (A400).....	91
3.3.13.1	Removing the IQ-Upcon 40 Module.....	91
3.3.13.2	Installing the IQ-Upcon 40 Module.....	92
3.3.14	Replacing the Step Attenuator (A500) – R&S SGU-B26.....	94
3.3.14.1	Removing the Step Attenuator	94
3.3.14.2	Installing the Step Attenuator	96
4	Firmware Update	98
5	USB Install	99
6	Documents.....	100
6.1	Spare Parts.....	100
6.1.1	Available Power Cables	100
6.2	Spare Part List and Mechanical Drawings.....	101
Index	102

1 Performance Test

Test Instructions

To ensure that rated specifications are maintained, the following preparations must be made prior to checking the rated characteristics:

- Check the instrument condition. Make sure the instrument fan operation is not constrained by dust etc. The fan can be inspected through the air intake at the case bottom side.
- Allow for a minimum warm-up time of 30 minutes at ambient temperature.
- Carry out all internal adjustments.
- The values are specified in the data sheet. Additional uncertainties introduced by the measurement equipment must be taken into account when checking the rated values.

This performance test describes the steps for testing the R&S SGU100A Signal Generator family and the installed options with respect to function and compliance with specifications.

In the following, the term DUT (Device Under Test) is used for any signal generator of this family. The tests to be performed depend on the installed options. The values are given in the data sheet of the respective instrument

1.1 Test Equipment

Table 1-1 *Measuring equipment and accessories*

Item	Type of equipment	Recommended characteristics or features	Recommended model	R&S Order No.
1	LO generator	10 MHz to 12.75 GHz	R&S SGS100A with frequency option B112V	1416.0505.02 1416.1576.02
2	Controller	Industry standard PC/XT/AT with IEC-60625 interface, USB interface, LAN interface and optional PCI Express interface		
3	Signal generator	1 MHz to RFmax	R&S SMB100A with adequate frequency option or R&S SMF100A with option R&S SMF-B2	1406.6000K03 1167.0000K02 1167.4005.02
4	Phase noise test assembly	included in RF analyzer item 16		
5	Oscilloscope	Bandwidth \geq 500 MHz, two channels with DC coupling	R&S RTM1052 or similar	1305.0008.52

6	RF power meter	10 MHz to RFmax	R&S NRP with R&S NRP-Z55 or R&S NRP-Z51	1143.8500.02 1138.2008.02 1138.0005.0x
7	Mixer	12 GHz to 40 GHz IF DC to 500 MHz		
8	VSWR bridge	1 MHz to 12.75 GHz directivity > 30 dB	f ≤ 4 GHz: R&S ZRC 3 GHz ≤ f ≤ 12.75 GHz: Agilent 773D	1039.9492.55
9	Pulse generator	Pulse repetition frequency ≥ 100 kHz	R&S SMB100A R&S SMBV or R&S SMF100A or R&S SMU equipped with pulse generator option	1406.6000K03 1407.6004K02 1167.0000K02 1141.2005.02
10	Arbitrary wave generator	two channels	R&S SMBV R&S SMU R&S AFQ	1407.6004K02 1141.2005.02
11	RF analyzer & Demodulator for analog modulations & Phase noise	1 MHz to 26/40 GHz	R&S FSUP 26 or R&S FSUP 50 depending on SGU100A frequency option	1166.3505.27 1166.3505.51
12	RF analyzer & Demodulator for analog and digital modulations	1 MHz to 26/40 GHz	R&S FSQ26 or R&S FSQ40 with options R&S FSU-B24 R&S FS-K7	1313.9100.40 1157.2100.50 1141.1796.02
13	Software for simulation of digital modulations	Generation of data for ARB generator	R&S WinIQSIM	
14	PCIe cable	PCIe extension cable with single lane connectors, length max. 5 m	One Stop Systems OSS-PCIe-CBL-x1 or Molex 74576-000x or equivalent	
15	PCIe device	External single lane PCIe device	R&S PCIe test port	5009.9002.02
16	Lowpass filter (2 pieces required)	Lowpass filter 2.5 MHz to remove WCDMA I/Q BB test signal noise Passband loss < 0.5 dB for f = 0...2 MHz Stopband loss > 15 dB for f > 3 MHz Linearity IP3 > 50 dBm		

1.2 Test Assemblies

1.2.1 Test Assembly for gen. spectrum and modulation measurements

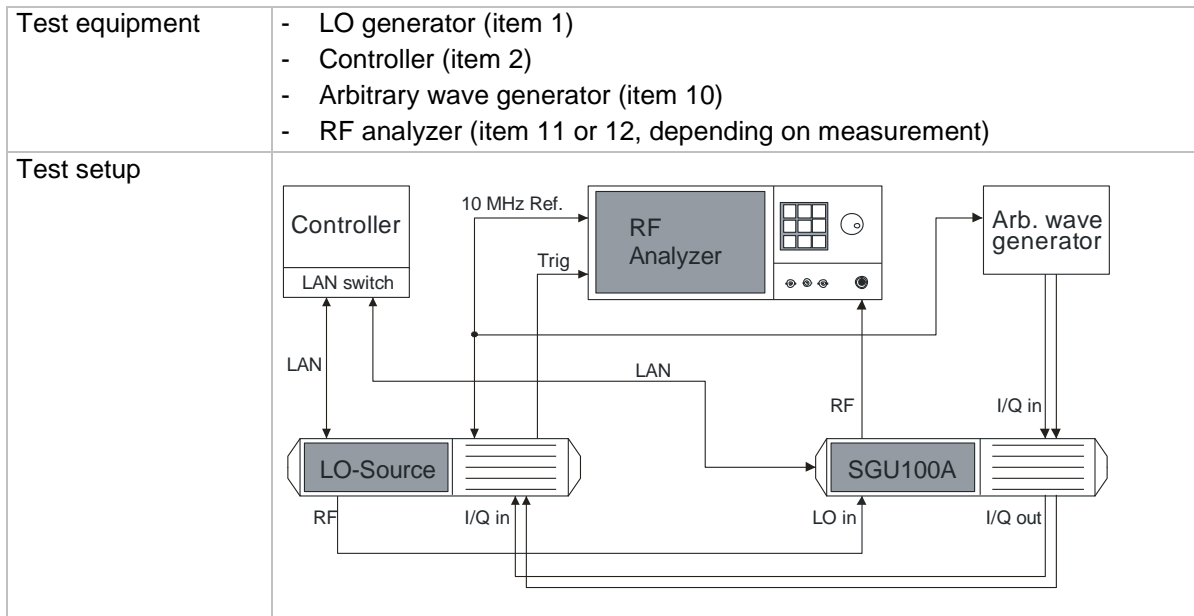

1.2.2 Test Assembly for Output Impedance (VSWR)

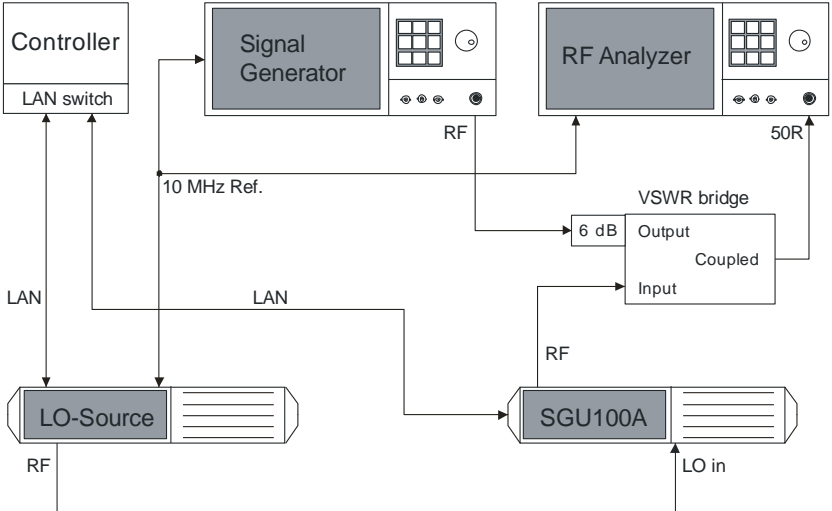
Test equipment	<ul style="list-style-type: none"> - VSWR bridge (item 8), - Signal generator (item 3) - RF analyzer (item 12)
Test setup	
	<p>Note: <i>The INPUT of the directional coupler is directly screwed to the DUT. The second signal generator is connected to the line connector (OUTPUT), the analyzer to the coupling output (COUPLED) of the directional coupler.</i></p>

1.2.3 Test Assembly for Setting Time

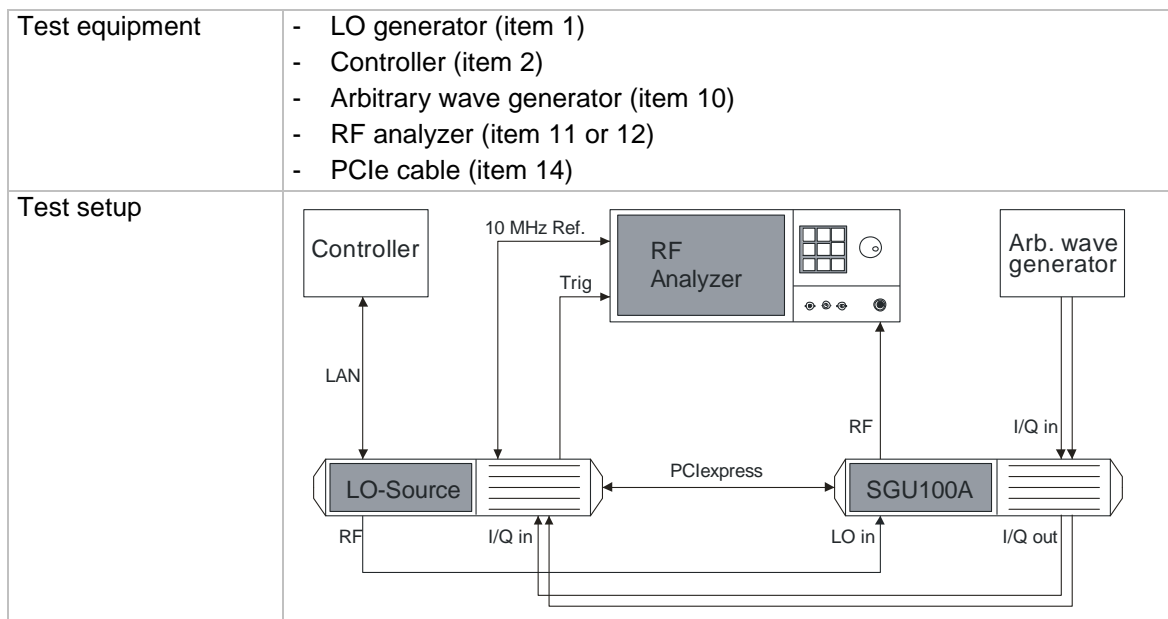

1.2.4 Test Assembly for Pulse Modulation

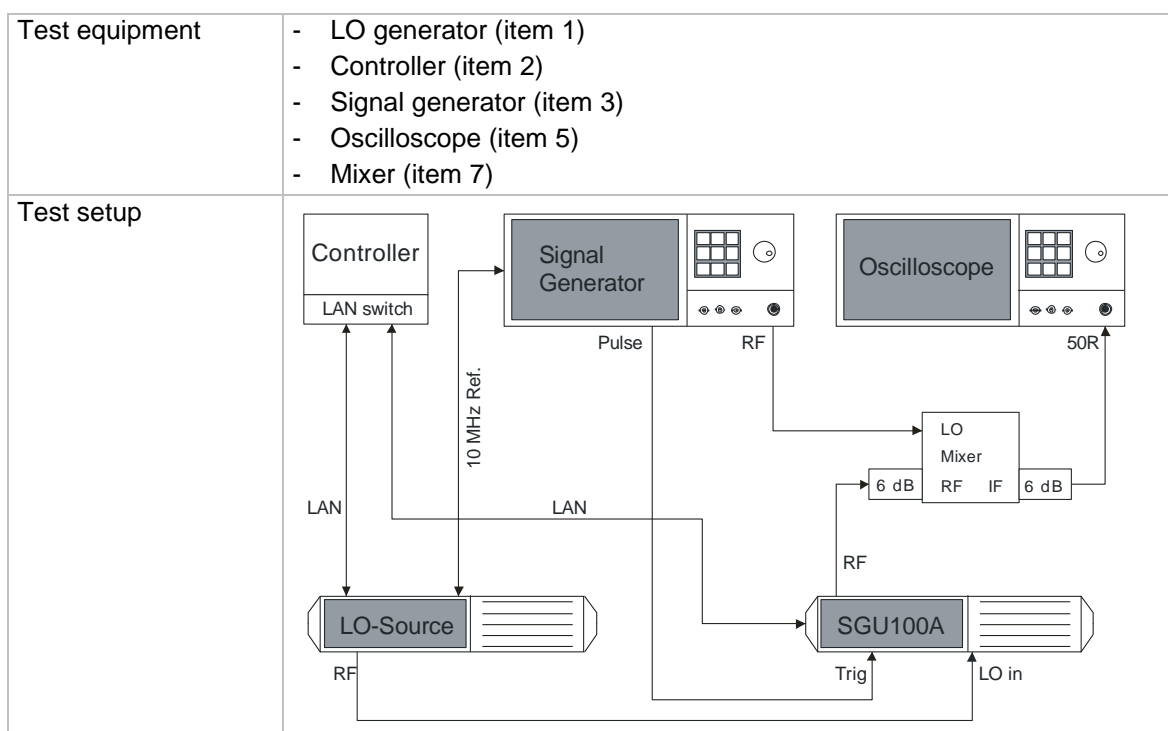

1.2.5 Test Assembly for Pulse Video Crosstalk

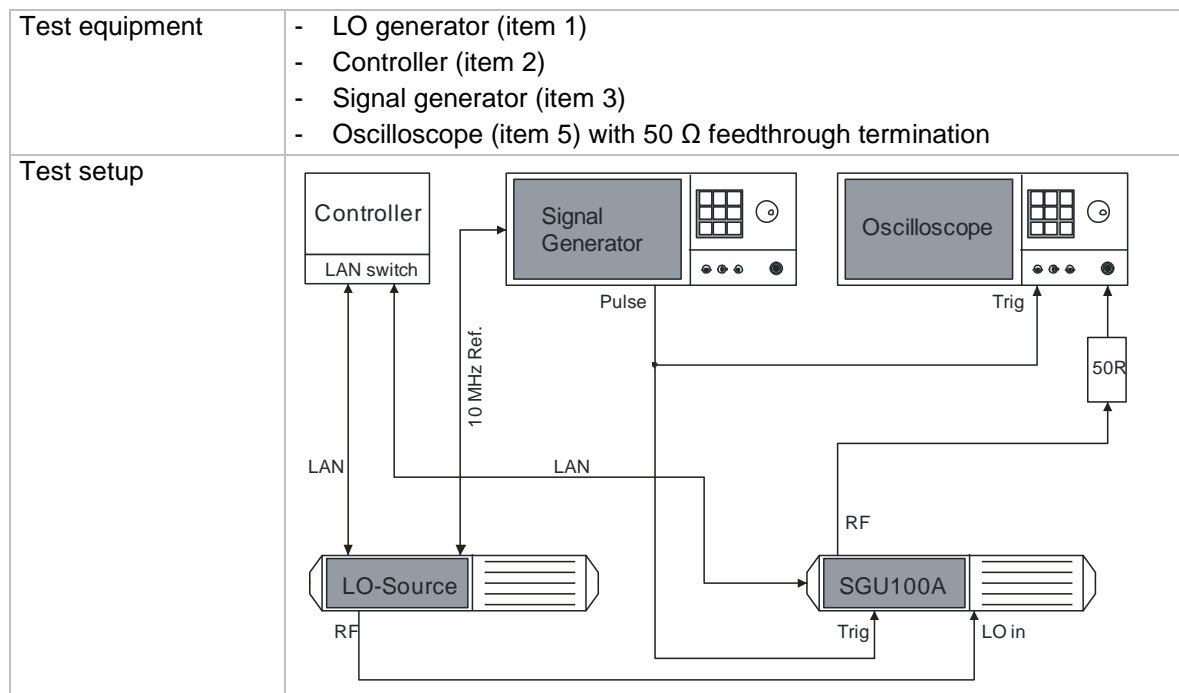

1.3 Preparation, Recommended Test Frequencies and Levels

To ensure proper conditions for the performance test and prevent setting errors, the instrument must be prepared as follows:

- Check the instrument condition. Make sure the instrument fan operation is not constrained by dust etc. The fan can be inspected through the air intake at the case bottom side.
- Allow for a minimum **warm-up time of 30 minutes** at ambient temperature.
- Carry out all **internal adjustments** (see operating manual, chapter 4, section "Internal Adjustment - Setup-System").
- Perform Preset to establish a defined **initial** state before configuring a new measurement.

The following sections describe the **procedures** for checking the rated values. The **values** are specified in the **data sheet**. Additional uncertainties introduced by the measurement equipment must be taken into account when checking the rated values.

The following table lists the important internal switch point frequencies and the recommended measurement frequencies derived from these frequencies. We recommend measurements at these frequencies unless particular test frequencies are specified. In the following, RF_{max} is the maximal settable RF (depending on installed options).

Table 1-2 Range limits, main test frequencies

Range	Frequency	Hardware switching points	Recommended test frequencies
Bypass	$10 \text{ MHz} \leq f \leq 12 \text{ GHz}$	6 GHz, 12 GHz	10 MHz, 20.01 MHz, 50.01 MHz, 80 MHz, 93.75 MHz, 120 MHz, 187.5 MHz, 265 MHz, 375 MHz, 530 MHz, 750 MHz, 1.06 GHz, 1.5 GHz, 2.12 GHz, 3 GHz, 4 GHz, 5 GHz, 6 GHz, 6.001 GHz, 7.2 GHz, 8.9 GHz, 10.7 GHz, 12 GHz
Doubler 20G	$12 \text{ GHz} < f \leq 20 \text{ GHz}$	12.75 GHz, 16 GHz, 19 GHz, 19.5 GHz, 20 GHz	12.01 GHz; 14.4 GHz, 16 GHz, 16.01 GHz, 17.5 GHz, 19 GHz, 19.01 GHz, 19.5 GHz, 20 GHz
Doubler 40G	$20 \text{ GHz} < f \leq 40 \text{ GHz}$	25.5 GHz, 25.7 GHz, 27 GHz, 32 GHz, 33.7 GHz, 38 GHz	20.01 GHz, 22.5 GHz, 25.5 GHz, 25.6 GHz, 25.71 GHz, 27.5 GHz, 30 GHz, 32 GHz, 32.01 GHz, 33.71 GHz, 35 GHz, 38 GHz, 38.01 GHz, 40 GHz

For **high-resolution measurements** in the entire frequency range, a logarithmic frequency grid in 1-2-5 sequence is recommended up to 50 MHz; above this value, linear 50 MHz steps should be used up to the upper limit frequency.

The recommended **test levels** are at the upper and lower switching threshold of the attenuator. The attenuator of the DUT is switched at fixed threshold levels in steps of 5 dB. The switching thresholds can be detected under **Attenuator fixed range** in the **Level** menu.

The level at which the attenuator fixed range changes is the threshold. By measuring at the last level setting of one range and the first level setting of the next range, the internal setting range borders are used. In the following, P_{\max} is the highest level before switching the attenuator, and P_{\min} is defined as $P_{\max} - 6$ dB for the step attenuator R&S SGU-B26.

1.4 Test Procedures

Note:

The measurement requires the correctly cabled combination of the SGU100A and a SGS100A LO source. The SGU100A must be registered in the SGS100A LO source as extension module. Remote control of the SGU100A operates through the SGS LO source. In the test description, the term 'DUT' is used for the combination of SGU100A and LO source.

1.4.1 Frequency Setting Time

Test assembly	See section 1.2.3.
Test method	<p>The spectrum analyzer operates as an FM demodulator. A controller transmits the start and the stop frequency via the LAN interface of the SGS100A LO source by a special remote command. The LO source trigger connector on the rear panel is programmed as trigger pulse output. The analyzer is triggered by the signal generated on the LO source trigger output. At switch over from start to stop frequency, the settling of the DUT output frequency is displayed on the screen of the analyzer.</p> <p>Note: To allow short setting times, the PCIe connection between SGS and SGU must be available. Make sure the PCIe channel is activated.</p>
Preparation of measurement	<ul style="list-style-type: none"> ➤ Synchronize the reference frequencies of the LO source and the analyzer. ➤ Make LAN, PCIe, Baseband and RF connections. ➤ Connect spectrum analyzer trigger connector to LO source trigger output ➤ Settings on DUT: <ul style="list-style-type: none"> - :CONNECTor:TRIGger:OMODE MLATency - Frequency: start frequency - Modulation: off - Level Settings/Setting Characteristic: Auto - Level: 5 dBm ➤ Settings on spectrum analyzer: <ul style="list-style-type: none"> - AMPT/REF LEVEL 5 dBm - FREQ/CENTER/STOP FREQUENCY - FM DEMOD ON - DEMOD BW 100 kHz - RANGE /DEVIATION PER DIV 200 Hz - MEAS TIME 4 ms - TRIGGER EXTERN - External triggering by positive edge at 1.4 V.

Measurement	<ul style="list-style-type: none">➤ Settings on analyzer: - Set the analyzer to the stop frequency➤ Set the DUT to the start frequency f_{start}➤ Send the stop frequency f_{stop} from the controller to the DUT by using the command :TEST:SPEED Stop frequency, Test level<ul style="list-style-type: none">⇒ The externally triggered analyzer displays the settling curve. The setting time is defined as the time required making the frequency deviation from the stop frequency less than the specified deviation in the data sheet. ➤ Switch on IQ-Modulation: I/Q Settings menu: Source Analog Wideband I/Q Input State On and supply 0.5 V DC to the I input of the SGU100A Repeat the measurement
-------------	--

Recommended test frequencies and modes	f_{start}	f_{stop}	Deviation	Mode
		500 MHz	6000 MHz	± 1200 Hz
	6000 MHz	500 MHz	± 100 Hz	CW, IQ
	500 MHz	6000.1 MHz	± 1200 Hz	CW, IQ
	6000.1 MHz	500 MHz	± 100 Hz	CW, IQ
	500 MHz	12001 MHz	± 2400 Hz	CW, IQ
	12001 MHz	500 MHz	± 100 Hz	CW, IQ
	500 MHz	20001 MHz	± 4000 Hz	CW, IQ
	20001 MHz	500 MHz	± 100 Hz	CW, IQ
	6000.1 MHz	12000 MHz	± 2400 Hz	CW, IQ
	12000 MHz	6000.1 MHz	± 1200 Hz	CW, IQ
	6000.1 MHz	12001 MHz	± 2400 Hz	CW, IQ
	12001 MHz	6000.1 MHz	± 1200 Hz	CW, IQ
	6000.1 MHz	20001 MHz	± 4000 Hz	CW, IQ
	20001 MHz	6000.1 MHz	± 1200 Hz	CW, IQ
	12001 MHz	20000 MHz	± 4000 Hz	CW, IQ
	20000 MHz	12001 MHz	± 2400 Hz	CW, IQ
	12001 MHz	20001 MHz	± 4000 Hz	CW, IQ
	20001 MHz	12001 MHz	± 2400 Hz	CW, IQ
	20001 MHz	40000 MHz	± 8000 Hz	CW, IQ
	40000 MHz	20001 MHz	± 4000 Hz	CW, IQ

Example of Measurement:

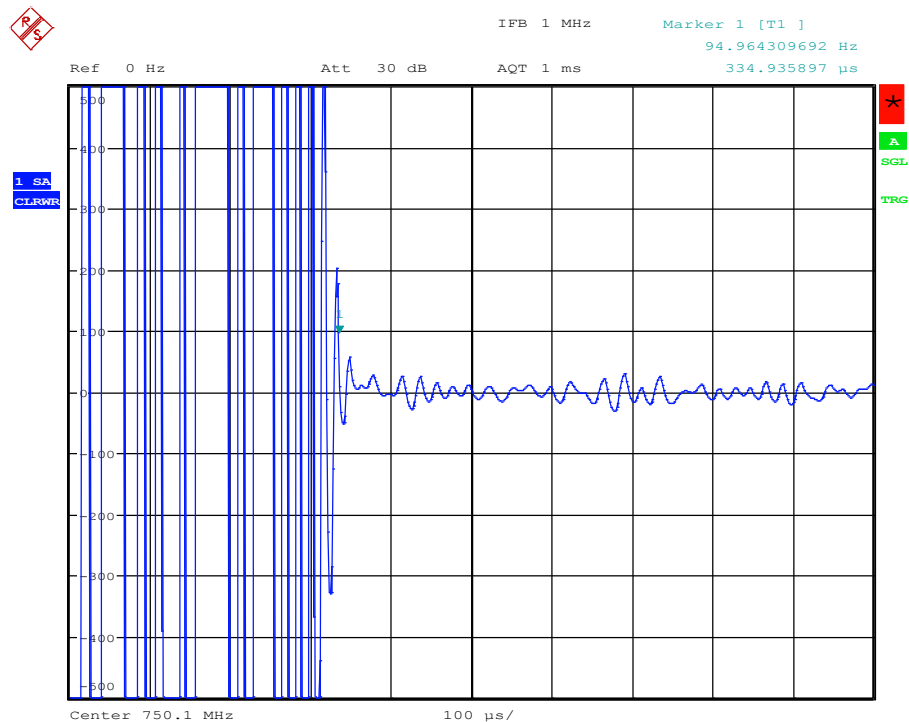

Date: 12.MAR.2012 16:08:54

The marker is set to the time when the trace enters the specified interval of 750.1 MHz \pm 150 Hz. The setting time is 335 μ s.

1.4.2 Spectral Purity

1.4.2.1 Harmonics

Test assembly	See section 1.2.1
Measurement	<ul style="list-style-type: none"> ➤ Settings on analyzer: Reference level = 20 dBm, 10 dB/div. Span 0 Hz, Resolution bandwidth 10 kHz ➤ Settings on DUT: - Frequency: test frequencies, unmodulated - Level: test levels ➤ First measure the level of the fundamental P_f at the test frequency f as a reference. Then measure the signal levels $P_{2\cdot f}$ and $P_{3\cdot f}$ at twice and three times the carrier frequency f. ⇒ The harmonic spacing is the measured harmonic level referred to the fundamental: $HD2 = P_f - P_{2\cdot f}$ $HD3 = P_f - P_{3\cdot f}$ (in dBc = referred to the carrier)
Recommended test frequencies and levels	<p>Test frequencies: 12001 MHz; 12750 MHz; 14000 MHz; 15000 MHz; 16000 MHz; 16001 MHz; 17000 MHz; 18000 MHz; 19000 MHz; 19001 MHz; 20000 MHz</p> <p>Test level: +8dBm</p> <p>Repeat the measurement with IQ-Modulation switched on: I/Q Settings menu: State On I/Q Wideband Off and supply 0.5 V DC to the I input of the SGU100A Test frequencies: 12001 MHz; 12750 MHz; 14000 MHz; 15000 MHz; 16000 MHz; 16001 MHz; 17000 MHz; 18000 MHz; 19000 MHz; 19001 MHz; 20000 MHz Test level: +8 dBm</p>

1.4.2.2 Subharmonics

Test assembly	See section 1.2.1
Measurement	<ul style="list-style-type: none"> ➤ First the level of the fundamental f_0 is measured as reference ➤ The level of the subharmonic signal is measured at the following frequencies <ul style="list-style-type: none"> • test subharmonics at $0.5 * f_0$, $1.5 * f_0$ • At instruments equipped with option B140 or B140V, additionally test subharmonics at $0.75 * f_0$, $1.25 * f_0$, $1.75 * f_0$ for fundamental frequencies $19.5 \text{ GHz} < f_0 \leq 40 \text{ GHz}$ ⇒ The subharmonic spacing is the measured level referred to the reference level (dBc = referred to the carrier).
Recommended test frequencies and levels	12.001 GHz, 12.125 GHz to 40 GHz in 125 MHz steps level: 0 dBm

1.4.2.3 Non systematic nonharmonics

Test assembly	See section 1.2.1
Measurement	<ul style="list-style-type: none"> ➤ Settings on DUT: <ul style="list-style-type: none"> - Test frequencies: 12.75 GHz; 16 GHz; 19 GHz; 20 GHz; 32 GHz; 39 GHz - Test level 0 dBm unmodulated ➤ Recommended settings on analyzer: <ul style="list-style-type: none"> - Max peak detector - Filter Type: FFT - Ref-Level 0 dBm ➤ - Set analyzer center frequency to test frequency, span to 40 MHz and resolution bandwidth to 2 kHz <ul style="list-style-type: none"> - Measure carrier level P - all signals other than the carrier must be below specified value - Set analyzer span to 100 kHz and resolution bandwidth to 200 Hz <ul style="list-style-type: none"> - all signals other than the carrier must be below P - 70dB ➤ Repeat the measurement with IQ-Modulation switched on: <ul style="list-style-type: none"> I/Q Settings menu: State On I/Q Wideband On and supply 0.5 V DC to the I input of the SGU100A

	<p>Note: <i>Some of the nonharmonics suppression values to be measured might be outside analyzer specifications. In case of doubt, repeat the measurement with a 3 dB attenuator pad at the analyzer input. If the nonharmonics suppression changes the nonharmonics are due to the analyzer. Because of the bell-shaped noise of the analyzer near the carrier, smaller resolution bandwidths may have to be used. To exclude amplitude independent nonharmonics of the analyzer, use a second generator with different synthesis architecture.</i></p>
--	---

1.4.2.4 Wideband Noise

Test assembly	See section 1.2.1
Test method	<p>The carrier power is measured first. Then the center frequency of the analyzer is increased by the desired frequency offset and the noise power in a small bandwidth is measured. The difference of the carrier power and the noise power in 1 Hz bandwidth, which is calculated from the measurement, is defined as wideband noise. Because wideband noise degrades with lower electronic levels at the output step attenuator input, the output level of the generator has to be set to the lowest level before switching the step attenuator.</p>

<p>Measurement</p>	<ul style="list-style-type: none"> ➤ Settings on DUT: <ul style="list-style-type: none"> - frequency: test frequency - Level: 10 dBm ➤ Settings on analyzer: <ul style="list-style-type: none"> - center: test frequency - reference level = DUT Level + 1 dB - Attenuator $D_{min} = DUT\ Level - P_{1dBm} + 5\ dB \Rightarrow$ round to next larger available Attenuation of the analyzer ($P_{1dBm} =$ analyzer P1dB level at test frequency) - span 110 kHz - Detector RMS - Sweep Time Manual 1s - switch on channel power measurement with 100 kHz bandwidth ➤ Determine the channel power with the center frequency of the analyzer set to the test frequency and note it down as P_{ref}. ➤ Increase the analyzer center frequency by 9.9 MHz for carrier frequencies up to 6 GHz and by 29.9 MHz for carrier frequencies > 6 GHz to 40 GHz. ➤ Inhibit the switching of the attenuator with AMPT RF ATTEN MANUAL without entering a value so that the input mixer is not overdriven. ➤ Lower the reference level of the analyzer by 20 dB, read the new channel power P_{noise}. ➤ Minimize the output level on the DUT by means of RF OFF, read the channel power P_{res}.
<p>Evaluation</p>	<ul style="list-style-type: none"> ➤ If the power $P_{res} < P_{noise} - 0.41\ dB$ the inherent noise power of the analyzer can be subtracted: $W_Noise = -P_{ref} + 10 * \log_{10}(10^{P_{noise}/10} - 10^{P_{res}/10}) - 50dB$ ➤ If the power $P_{res} > P_{noise} - 0.41\ dB$ the analyzer resolution is not sufficient for a precise measurement. The true result is in such case certainly more than 10 dB below the measured value. The result then is at least: $W_Noise = -P_{ref} + P_{noise} - 50\ dB - 10\ dB.$ <p>\RightarrowThe difference between the (possibly corrected) power P_{noise} in dBm and the power P_{ref} in dBm is the broadband noise floor in dBc.</p>

Recommended test frequencies	<ul style="list-style-type: none"> ➤ 12001 MHz; 12750 MHz; 13000 MHz; 14000 MHz; 15000 MHz; 16000 MHz; 16001 MHz; 17000 MHz; 18000 MHz; 19000 MHz; 19001 MHz; 19500 MHz; 19501 MHz; 20000 MHz; 20001 MHz; 21000 MHz; 22000 MHz; 23000 MHz; 24000 MHz; 25000 MHz; 26000 MHz; 27000 MHz; 27001 MHz; 28 GHz to 40 GHz in steps of 1 GHz ➤ Repeat the measurement with IQ-Modulation switched on: I/Q Settings menu: State On I/Q Wideband On and supply 0.5 V DC to the I input of the SGU100A
------------------------------	--

1.4.2.5 Residual AM

Test assembly	See section 1.2.1
Test method	The FM demodulator of the analyzer is used to AM-demodulate the CW signal of the DUT. By setting the AF low-pass and high-pass filters the RMS value in the desired bandwidth can be measured. The value displayed is the sum of the analyzer residual AM and the DUT residual AM. Because they are uncorrelated, the displayed result is worse than residual RMS of the DUT alone. Therefore, if the sum is in tolerance according to the data sheet the DUT is also in tolerance.
Measurement	<ul style="list-style-type: none"> ➤ Settings on DUT: <ul style="list-style-type: none"> - frequency: 12.75 GHz - Level: 0 dBm ➤ Settings on analyzer: <ul style="list-style-type: none"> - CENTER: test frequency - REFERENCE LEVEL: 1 dBm - AMPT ⇒ RF ATTEN MANUAL: 10 dB - FM DEMOD - FM DEMOD ⇒ RESULT DISPLAY ⇒ AM - FM DEMOD ⇒ MEAS TIME: 100ms - FM DEMOD ⇒ DEMOD BW: 200 kHz - FM DEMOD ⇒ AF-FILTER ⇒ HIGH PASS AF FILTER: 20 Hz - FM DEMOD ⇒ AF-FILTER ⇒ LOW PASS AF FILTER: 20 kHz - SETUP ⇒ SIGNAL SOURCE ⇒ YIG FILTER: OFF ➤ The Residual AM in the frequency range 20 Hz – 23 kHz is the RMS value displayed.
Test frequencies	12.75 GHz, 16 GHz, 16.01 GHz, 19 GHz, 19.01 GHz, 19.99 GHz, 20.01 GHz, 25.01 GHz, 32.01 GHz, 38.01 GHz, 40 GHz

Example:

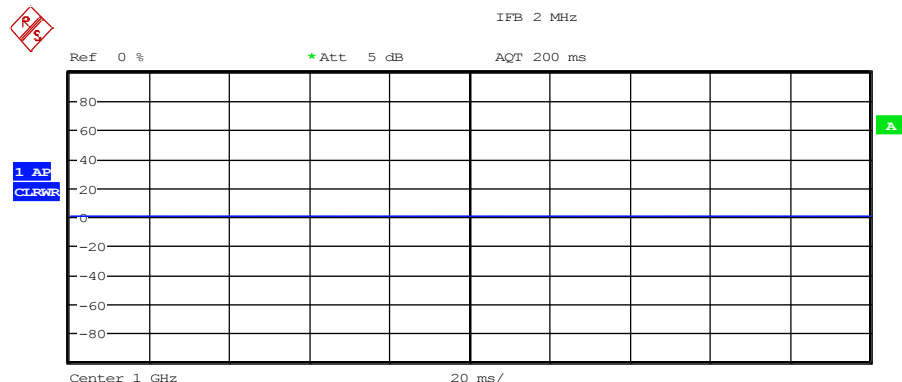

Amplitude Modulation Summary

Modulation Depth	0.022 %	Carrier Power	-0.87 dBm
Modulation +peak	0.022 %	Modulation Frequency	--- Hz
-peak	-0.023 %	Sampling Rate	250 kHz
+peak/2	0.022 %	Record Length	50001
RMS	0.005 %	Demod Bandwidth	200 kHz
		AF Filter	HP 20 Hz
			LP 23 kHz

Date: 25.FEB.2008 16:33:44

Residual AM = 0.005 %

1.4.3 Level Data

1.4.3.1 Level Uncertainty

Test method	The level uncertainty is measured in two steps. First, the frequency response is measured at a fixed level with high frequency resolution. Then the level dependent uncertainty is measured at fixed frequencies over the specified range.
Test equipment	<ul style="list-style-type: none"> - RF power meter (item 6) - RF analyzer (item 11 or 12)

Test method for levels in measurement range of power meter

Test setup	Connect power meter to RF output socket.
Measurement	<ul style="list-style-type: none"> ➤ Setting on DUT: <ul style="list-style-type: none"> - Levels : test level - Level Settings⇒Setting Characteristic: Auto ➤ Measure the level P_{absolute} at the recommended test frequencies up to RF_{max}. <ul style="list-style-type: none"> ⇒ The level error is the deviation of the measured level from the set value. ➤ Repeat the measurement with IQ-Modulation switched on: <ul style="list-style-type: none"> I/Q Settings menu: State On I/Q Wideband On and supply 0.5 V DC to the I input of the SGU100A
Recommended test levels for frequency response measurement	<p>Option R&S SGU-B26: maximum specified level, 0 dBm</p> <p>Without Option R&S SGU-B26: maximum specified level, minimum specified level</p>
Recommended test frequencies for the level frequency response measurement	12012.5 MHz to RF_{max} in 25 MHz Steps
Measurement of level dependent uncertainty for instruments with no step attenuator (w/o R&S SGU-B26)	
Recommended test levels	maximum specified level down to -10 dBm in 3 dB steps
Recommended test frequencies.	12012.5 MHz, 12787.5 MHz, 14150 MHz, 15550 MHz, 16150 MHz, 17050 MHz, 18050 MHz, 20000 MHz, 21750 MHz, 22950 MHz, 24250 MHz, 25850 MHz, 27550 MHz, 28950 MHz, 30250 MHz, 31150 MHz, 32250 MHz, 33250 MHz, 34250 MHz, 35250 MHz, 36250 MHz, 37250 MHz, 38150 MHz, 39150 MHz, 39950 MHz

Test method for measurement of level dependent uncertainty at low levels for instruments equipped with step attenuator (opt. R&S SGU-B26)

Test principle	<p>Low levels can only be measured using a frequency selective measurement instrument. Spectrum analyzers with digital IF are best suited for this measurement due to their low linearity error. The absolute accuracy of these analyzers is not sufficient for this measurement. So a relative measurement referred to the measurements performed with the power meter is used to increase the accuracy of the measurement.</p> <p>Only by switching the input attenuator and preamplifier (when available) of the analyzer the needed dynamic range of more than 120 dB can be reached. After switching the analyzer attenuator or preamplifier, a continuity calibration is to be carried out. It is therefore recommended to switch the attenuator not until reaching 50 dB under full scale, since the linearity errors are very small in this range.</p>
Test assembly	<p>See section 1.2.1</p> <p>Connect the spectrum analyzer to the RF output of the DUT with precision RF measurement cables.</p>
Measurement	<ul style="list-style-type: none"> ➤ Settings on DUT <ul style="list-style-type: none"> Frequency recommended test frequencies Level maximum specified level, unmodulated ➤ Setting on the analyzer <ul style="list-style-type: none"> Test frequency SPAN 10 Hz FILTER TYPE FFT RES BW 5 Hz set Marker to test frequency Reference level $P_{ref} = +17$ dBm ➤ Read the marker level P_{Marker} and calculate the correction factor $C = P_{absolute} - P_{Marker}$ <ul style="list-style-type: none"> with $P_{absolute}$ from the measurements performed with the power meter. ➤ Now decrease the DUT level in 5 dB steps and calculate the output power P by adding the Correction factor C to the marker readout. ➤ As soon as the marker level P_{Att1} is lower than $P_{ref} - 45$ dB increase the sensitivity of the analyzer by reducing the input attenuation, switching on the internal preamplifier if available and reducing the resolution bandwidth to 1 Hz for levels below -90 dBm. Set the analyzer reference level to $P_{Att1} + 1$ dB. After switching the analyzer sensitivity read out the marker level P_{Att2} and recalculate the Correction factor: $C_{new} = C_{old} + P_{Att1} - P_{Att2}$ ➤ Continue the measurement down to -100 dBm in 5 dB steps.

Recommended test frequencies.	12012.5 MHz, 12787.5 MHz, 14150 MHz, 15550 MHz, 16150 MHz, 17050 MHz, 18050 MHz, 20000 MHz, 21750 MHz, 22950 MHz, 24250 MHz, 25850 MHz, 27550 MHz, 28950 MHz, 30250 MHz, 31150 MHz, 32250 MHz, 33250 MHz, 34250 MHz, 35250 MHz, 36250 MHz, 37250 MHz, 38150 MHz, 39150 MHz, 39950 MHz
-------------------------------	---

1.4.3.2 Output Impedance

Test assembly	See section 1.2.2
Test method	For the VSWR measurement of a source the effect of the level control must be taken into account. For this purpose, an auxiliary generator is used which transmits a wave with a slightly offset carrier frequency into the DUT. The difference frequency has to be within the control bandwidth of the level control. In the case of ideal source impedance, the wave from the auxiliary generator is not reflected by the DUT. In the case of not ideal DUT source impedance, the output wave of the DUT and the reflected wave of the auxiliary generator are superimposed on one another. A directional coupler couples a part of these outgoing superimposed waves to an analyzer. The frequency offset, results in a beat of the superimposed outgoing waves. The VSWR is the ratio between the maximum and minimum amplitude of the beat.
Measurement	<ul style="list-style-type: none"> ➤ Settings on DUT: <ul style="list-style-type: none"> - Level: test level - Frequency: test frequency, unmodulated - Increase the level control bandwidth using the command CALibration:LEVel:BWIDth HIGH ➤ Settings on spectrum analyzer: <ul style="list-style-type: none"> - Test frequency, span 0 Hz, test level - Resolution and video bandwidth 10 kHz - Linear level scale - Sweep time 20 ms ➤ Settings on second signal generator: <ul style="list-style-type: none"> - set the frequency to the test frequency – 100 Hz, - set minimum level, unmodulated. ➤ Vary the reference level to bring the line displayed on the screen of the spectrum analyzer approximately into the middle of the screen. Measure the voltage of the signal V_{ref}. ➤ Unscrew the VSWR bridge from the DUT and let the test port open. Increase the level of the second signal generator until the voltage on the analyzer is $V_{ref} \pm 0.5\%$. ➤ Screw the VSWR bridge onto the DUT again. ➤ Measure the maximum voltage V_{max} and minimum voltage V_{min} of the sinusoidal trace. Calculate the VSWR: $VSWR = V_{max}/V_{min}$

<p>Recommended test frequencies and levels</p>	<ul style="list-style-type: none"> ➤ Test frequencies: from 10 MHz every 50 MHz up to RF_{max}. ➤ Test levels for instruments equipped with Option R&S@SGU-B26: <ul style="list-style-type: none"> - set Attenuator Settings Mode "AUTO" - set level to maximum specified level - set Attenuator Settings Mode "FIXED" - set level to 0 dBm <p>Test level for instruments without Option R&S@SGU-B26: 0 dBm</p>
--	---

1.4.3.3 Setting Time

<p>Test assembly</p>	<p>See section 1.2.3.</p>
<p>Test method</p>	<p>The RF analyzer is operated as a fast level meter in zero span. A controller transmits the start and the stop level via the LAN interface by a special remote command. The LO source trigger connector on the rear panel is programmed as trigger pulse output. The analyzer is triggered by the signal generated on the LO source trigger output. At switch over from start to stop level, the settling procedure is displayed on the screen of the analyzer.</p> <p><i>Note: To allow short setting times, the PCIeexpress connection between SGS and SGU must be available. Make sure the PCIeexpress channel is activated.</i></p>
<p>Preparation of measurement</p>	<ul style="list-style-type: none"> ➤ Synchronize the reference frequencies of the LO source and the analyzer. ➤ Make LAN, PCIeexpress, Baseband and RF connections. ➤ Connect the spectrum analyzer trigger input to the LO source trigger output ➤ Setting on LO source: <ul style="list-style-type: none"> - :CONNector:TRIGger:OMODe MLATency - Frequency: test frequency - Level: start level ➤ Settings on spectrum analyzer: <ul style="list-style-type: none"> - REFERENCE LEVEL: target level + 3 dB - AMPLITUDE LOG RANGE 10 dB - RESOLUTION BANDWIDTH 200 kHz - VIDEO BANDWIDTH 2 MHz - SPAN 0 Hz - SWEEP TIME: 1 s / 4 ms - TRIGGER EXTERN - External triggering by positive edge at 1.4 V.

<p>Measurement</p>	<ul style="list-style-type: none"> ➤ Send the stop level from the controller to the DUT by using the command :TEST:SPEED Test frequency, Stop level. ⇒ The externally triggered analyzer displays the settling curve. The settling time is defined as the time from which on the level deviation from the final level (1 second after switch over) is less than the specified deviation in the data sheet. ➤ Measure the following steps in CW mode ➤ Measure the following steps with with IQ-Modulation switched on: I/Q Settings menu: State On I/Q Wideband On and supply 0.5 V DC to the I input of the SGU100A 																						
<p>Recommended test frequencies and levels</p>	<p>Frequencies: 10 MHz, 79.99 MHz, 80.01 MHz, 375 MHz, 1.1 GHz, 4.5 GHz, 6.1 GHz, 7.5 GHz, 10 GHz, 12.01 GHz, 12.75 GHz, 14.4 GHz, 16 GHz, 20 GHz, 26 GHz, 30 GHz, 35 GHz, 40 GHz</p> <p>Measure with level setting characteristic Auto:</p> <table border="1" data-bbox="802 994 1445 1193"> <thead> <tr> <th>Start level</th> <th>Stop level</th> <th>Remark</th> </tr> </thead> <tbody> <tr> <td>-10 dBm</td> <td>maximum specified level</td> <td rowspan="2">Only for instruments without option R&S SGU-B26</td> </tr> <tr> <td>maximum specified level</td> <td>-10 dBm</td> </tr> </tbody> </table> <p>Measure with level setting characteristic Uninterrupted level setting. Before executing the transition from start level to stop level, readjust the level setting at the maximum test level: Level ⇒ Level Settings ⇒ Readjust</p> <table border="1" data-bbox="802 1384 1445 1606"> <thead> <tr> <th>Start level</th> <th>Stop level</th> <th>Remark</th> </tr> </thead> <tbody> <tr> <td>0 dBm</td> <td>maximum specified level</td> <td rowspan="2">Only for instruments equipped with option R&S SGU-B26</td> </tr> <tr> <td>maximum specified level</td> <td>0 dBm</td> </tr> </tbody> </table> <p>Measure with level setting characteristic Auto. Increase the sweep time to 100 ms:</p> <table border="1" data-bbox="802 1713 1445 1930"> <thead> <tr> <th>Start level</th> <th>Stop level</th> <th>Remark</th> </tr> </thead> <tbody> <tr> <td>-120 dBm</td> <td>maximum specified level</td> <td>Only for instruments equipped with option R&S SGU-B26</td> </tr> </tbody> </table>	Start level	Stop level	Remark	-10 dBm	maximum specified level	Only for instruments without option R&S SGU-B26	maximum specified level	-10 dBm	Start level	Stop level	Remark	0 dBm	maximum specified level	Only for instruments equipped with option R&S SGU-B26	maximum specified level	0 dBm	Start level	Stop level	Remark	-120 dBm	maximum specified level	Only for instruments equipped with option R&S SGU-B26
Start level	Stop level	Remark																					
-10 dBm	maximum specified level	Only for instruments without option R&S SGU-B26																					
maximum specified level	-10 dBm																						
Start level	Stop level	Remark																					
0 dBm	maximum specified level	Only for instruments equipped with option R&S SGU-B26																					
maximum specified level	0 dBm																						
Start level	Stop level	Remark																					
-120 dBm	maximum specified level	Only for instruments equipped with option R&S SGU-B26																					

1.4.4 Pulse Modulation

1.4.4.1 ON/OFF Ratio

Test assembly	See section 1.2.1
Test setup	<ul style="list-style-type: none"> ➤ Leave the TRIG connector of the SGU100A and the TRIG connector of the SGS100A LO source unconnected.
Measurement	<ul style="list-style-type: none"> ➤ Setting on DUT: RF On Level 0 dBm Frequency recommended test frequencies Pulse Modulation menu: State On Polarity Inverse ➤ Setting on Analyzer FREQ/CENTER test frequency SPAN 0 Hz AMPT/REF LEVEL 0 dBm BW ⇒ RES BW MANUAL 3 kHz SWEEP ⇒ SWEEP TIME MANUAL 100 ms MEAS ⇒ TIME DOM POWER on ➤ Determine the output level of the DUT at the recommended test frequencies with Pulse Modulation ⇒ Polarity Inverse and Pulse Modulation ⇒ Polarity Normal. ⇒ The level difference between the output level with Polarity Inverse and Polarity Normal is the ON/OFF ratio.
Recommended test frequencies	<ul style="list-style-type: none"> ➤ Instruments without Option R&S SGU-B140(V): 12.001 GHz to 20 GHz in steps of 100 MHz ➤ Instruments equipped with Option R&S SGU-B140(V) when SGS100A LO Source is equipped with Option R&S SGS-K22: 12.001 GHz to Fmax in steps of 100 MHz ➤ Instruments equipped with Option R&S SGU-B140(V) when SGS100A LO Source is without Option R&S SGS-K22: 12.001 GHz to 19.5 GHz in steps of 100 MHz
Recommended test level	<ul style="list-style-type: none"> ➤ Instruments equipped with Option R&S SGU-B26: - set level to 5 dBm, - set ATT Mode fixed - determine P_{min} , - set level to P_{min} ➤ Instruments without Option R&S SGU-B26: 0 dBm

1.4.4.2 Rise/ Fall Time and Pulse Overshoot

Test assembly	See section 1.2.4
Test method	The RF signal is down converted to 0 Hz in phase. Thus, the mixer IF output reproduces the RF amplitude vs. time.
Measurement	<ul style="list-style-type: none"> ➤ Setting on pulse generator: For adjustment statically high level, for measurement square wave pulse sequence with a frequency of 1 MHz, TTL level ➤ Setting on DUT: RF On Level 0 dBm Frequency recommended test frequencies Pulse Modulation menu: State On ➤ Setting on Signal Generator: RF On Level recommended LO-Level of Mixer Frequency same as DUT ➤ Setting on oscilloscope: Adjust V/div according to the mixer in use Time base 20 ns/div Trigger: - for adjustment free running, - for measurement 50 % of signal amplitude, rising and falling edge. ➤ Adjustment: At each test frequency adjust phase using menu Frequency/Phase / Delta Phase. Vary the Delta Phase to obtain maximal signal output at the mixers IF port. The voltage at maximum corresponds to 100 % of RF amplitude. ➤ Measurement: Evaluate the down converted pulse-modulated signal on the oscilloscope: Rise time = time between 10% and 90% of signal amplitude Fall time = time between 90% and 10% of signal amplitude Pulse Overshoot: Determine the peak value of demodulated signal V_{peak} and the signal level of settled pulse $V_{settled}$ $\text{Pulse Overshoot [in \%]} = 100 * \frac{V_{Peak} - V_{settled}}{V_{settled}}$

<p>Recommended test frequencies</p>	<ul style="list-style-type: none"> ➤ Instruments without Option R&S SGU-B140(V): 12.001 GHz to 20 GHz in steps of 1 GHz ➤ Instruments equipped with Option R&S SGU-B140(V) when SGS100A LO Source is equipped with Option R&S SGS-K22: 12.001 GHz to Fmax in steps of 1 GHz ➤ Instruments equipped with Option R&S SGU-B140(V) when SGS100A LO Source is without Option R&S SGS-K22: 12.001 GHz to 19 GHz in steps of 1 GHz
-------------------------------------	--

1.4.4.3 Video Crosstalk

<p>Test assembly</p>	<p>See section 1.2.5</p>
<p>Measurement</p>	<ul style="list-style-type: none"> ➤ Setting on pulse generator: Square wave pulse sequence with a frequency of 100 kHz, TTL level ➤ Setting on DUT: RF On Frequency recommended test frequencies Level recommended test levels Pulse Modulation menu: State On ➤ Settings on the oscilloscope Amplitude 150 mV/Div Sweep Time 10 ns/Div Bandwidth 500MHz Trigger Offset -20 ns Trigger Source Trigger Input Trigger Level 1.4 V Trigger Slope positive ➤ Measure the peak to peak signal level at the rising edge of the pulse. Set trigger slope to negative and measure the peak to peak signal level at the falling edge of the pulse. ⇒ The peak to peak value at the rising and the falling edge have to be below the guaranteed video crosstalk.

<p>Recommended test frequencies and levels</p>	<ul style="list-style-type: none"> ➤ Instruments without Option R&S SGU-B140(V): Test frequencies 12.001 GHz, 20 GHz with Test levels 3.01 dBm, 10 dBm, 15 dBm ➤ Instruments equipped with Option R&S SGU-B140(V) when SGS100A LO Source is equipped with Option R&S SGS-K22: Test frequencies 12.001 GHz, 19.5 GHz with test levels 3.01 dBm, 10 dBm, 13 dBm Test frequencies 20 GHz, 40 GHz with test levels 3.01 dBm, 9 dBm ➤ Instruments equipped with Option R&S SGU-B140(V) when SGS100A LO Source is without Option R&S SGS-K22: Test frequencies 12.001 GHz, 19.5 GHz with Test levels 3.01 dBm, 10 dBm, 15 dBm
--	--

1.4.5 I/Q modulation

1.4.5.1 Input Impedance (VSWR)

<p>Test assembly</p>	<p>See section 1.2.2</p>
<p>Test method</p>	<ul style="list-style-type: none"> ➤ Same as for the output impedance of the DUT.
<p>Test setup</p>	<ul style="list-style-type: none"> ➤ Connect the test port of the VSWR bridge to the I or Q input of the SGU100A instead of the RF output.
<p>Measurement</p>	<ul style="list-style-type: none"> ➤ Settings on DUT: Frequency 15 GHz RF on Level 0 dBm (PEP) I/Q Settings menu: State On I/Q Wideband On, ➤ Settings on signal generator: - Level: 10 dBm - Frequency: test frequencies ➤ Let the measuring port of the VSWR bridge unconnected and measure the level P_{ref} as reference level. ➤ Connect the VSWR bridge to the I input and measure the level P_I. ➤ Calculate the VSWR: $VSWR = \frac{1 + \sqrt{P_I / P_{ref}}}{1 - \sqrt{P_I / P_{ref}}}$ ➤ Repeat the measurement for the Q input. ➤ Set the RF frequency to 30 GHz and repeat the measurement for the I and Q input.

Recommended test frequencies	➤ I/Q: 1 MHz, 10 MHz, 20 MHz, 40 MHz, 60 MHz, 80 MHz, 100 MHz, 150 MHz to 1000 MHz in steps of 50 MHz
------------------------------	---

1.4.5.2 Dynamic Error Vector

Test assembly	See section 1.2.1 RF analyzer with digital demodulation (item 12) is required
Measurement	<ul style="list-style-type: none"> ➤ Settings on DUT: <ul style="list-style-type: none"> RF On Level 0 dBm (PEP) I/Q Settings menu: <ul style="list-style-type: none"> State On I/Q Wideband Off ➤ Generate a modulation signal on the ARB generator using the controller and the simulation program: <ul style="list-style-type: none"> - Modulation 16QAM - No coding - SQR COS filter with $\alpha = 0.5$ - PRBS-9 data sequence - Pulse width and over sampling 32 - Length 1000 symbols - Symbol clock 10 MHz ➤ Check if the channels on the ARB generator are equal and adjust if necessary. ➤ Make the corresponding settings on the demodulator. Result length 800 symbols. ➤ Measure the error vector magnitude (peak and rms) at the recommended test frequencies.
Recommended test frequencies	12.5 GHz to RFmax in steps of 500 MHz

1.4.5.3 Residual Carrier and Leakage

Test assembly	See section 1.2.1
Measurement	<ul style="list-style-type: none"> ➤ Settings on DUT: <ul style="list-style-type: none"> RF On Frequency test frequency Level 0 dBm Level menu: <ul style="list-style-type: none"> ALC State Off(Table) I/Q Settings menu: <ul style="list-style-type: none"> State Off I/Q Wideband Off ➤ Settings on analyzer: <ul style="list-style-type: none"> FREQ/CENTER = test frequency, SPAN 1 MHz, AMPT/REF LEVEL = test level ➤ First measure the unmodulated level P_{ref} as a reference. ➤ Then switch on I/Q modulation with 50 Ohm terminated I- and Q-inputs (I/Q Settings menu: State On) and measure the residual carrier level $P_{carrier}$. <ul style="list-style-type: none"> ⇒ The carrier suppression in dBc is: <ul style="list-style-type: none"> $D_{carrier} = P_{ref} - P_{carrier}$ in dBc = referred to the carrier. ➤ Set Impairments State to On and Leakage to 5% on the DUT. Measure the residual carrier. <ul style="list-style-type: none"> ⇒ The residual carrier should increase to 5% (-26 dBc).
Recommended test frequencies	<ul style="list-style-type: none"> ➤ Residual carrier measurement: <ul style="list-style-type: none"> 12.0125 GHz to RFmax in 50 MHz steps ➤ Leakage 2% measurement: <ul style="list-style-type: none"> 12 GHz to RFmax in 200 MHz steps

1.4.5.4 I/Q Imbalance

Test assembly	See section 1.2.1
Measurement	<ul style="list-style-type: none"> ➤ Settings on DUT: <ul style="list-style-type: none"> RF On Frequency test frequency Level 0 dBm (PEP) Level menu: <ul style="list-style-type: none"> ALC State Off(Table) I/Q Settings menu: <ul style="list-style-type: none"> State On I/Q Wideband Off Impairments State on Imbalance 1.0 dB ➤ Settings on analyzer: <ul style="list-style-type: none"> - Center frequency = test frequency, span 1 MHz - Reference level = test level +3 dB - Scale 1 dB/div ➤ Apply a DC voltage of 0.5 V to the I-input and 0V to the Q-input. Measure the output level P_I. Then apply a DC voltage of 0.5 V to the Q-input and 0V to the I-input. Measure the level P_Q. The Imbalance is: $\text{Imbalance} = P_I - P_Q$ <ul style="list-style-type: none"> ⇒ The Imbalance should show a value of 1 dB. ➤ Change the DUT Imbalance setting to -1.0 dB <ul style="list-style-type: none"> ⇒ The measured Imbalance should show a value of -1 dB.
Recommended test frequencies	<ul style="list-style-type: none"> ➤ 12.001 GHz, 16 GHz, 20 GHz, 20.001 GHz, 30 GHz, 40 GHz

1.4.6 Phase Coherence Levels

Test equipment	- Signal generator (item 3) - RF power meter (item 6)
Test assembly	The Signal generator is connected to the LO IN-connector of the SGU100A and the RF power meter is connected to LO OUT-connector of the SGU100A.
Test method	A LO-signal from the signal generator is fed into the LO input. The power at the LO-out SMA-connector is measured with the power meter.
Measurement	<ul style="list-style-type: none"> ➤ Settings on DUT: RF: State ON Level: 0 dBm Frequency: test frequencies ➤ Setting on second signal generator: - Level: + 7 dBm / + 13 dBm - Frequency: LO test frequencies - RF: State ON ➤ Set the frequency of the DUT and signal generator to the recommended test frequencies. Set the level of the second signal generator to +7 dBm and measure the level $P_{+7 \text{ dBm}}$. Set the level of the second signal generator to +13 dBm and measure the level $P_{+13 \text{ dBm}}$. <ul style="list-style-type: none"> ⇒ The level $P_{+7 \text{ dBm}}$ and $P_{+13 \text{ dBm}}$ should be +10 dBm \pm 3 dB ⇒ The level difference between $P_{+13 \text{ dBm}}$ and $P_{+7 \text{ dBm}}$ should be less than \pm 2 dB <p>At both test levels, the DUT should report no errors concerning the LO level.</p>
Recommended test frequencies	<p>DUT test frequencies: $f = 12.001 \text{ GHz}$ to 40 GHz in steps of 200 MHz</p> <p>LO in and LO out frequencies for instruments equipped without B140(V):</p> <ul style="list-style-type: none"> • $12 \text{ GHz} < f \leq 12.75 \text{ GHz}$: $f_{\text{LOin}} = f * 1$, $f_{\text{LOout}} = f * 1$ • $12.75 \text{ GHz} < f \leq 20 \text{ GHz}$: $f_{\text{LOin}} = f * 0.5$, $f_{\text{LOout}} = f * 1$ <p>LO in and LO out frequencies for instruments equipped with B140(V):</p> <ul style="list-style-type: none"> • $12 \text{ GHz} < f \leq 12.75 \text{ GHz}$: $f_{\text{LOin}} = f * 1$, $f_{\text{LOout}} = f * 1$ • $12.75 \text{ GHz} < f \leq 19 \text{ GHz}$: $f_{\text{LOin}} = f * 0.5$, $f_{\text{LOout}} = f * 1$ • $19 \text{ GHz} < f \leq 25.5 \text{ GHz}$: $f_{\text{LOin}} = f * 0.5$, $f_{\text{LOout}} = f * 0.5$ • $25.5 \text{ GHz} < f \leq 40 \text{ GHz}$: $f_{\text{LOin}} = f * 0.25$, $f_{\text{LOout}} = f * 0.5$

1.4.7 PCI Express Interface

Test equipment	<ul style="list-style-type: none">- PCIe test port (item 15)- PCIe cable (item 14)
Test assembly	External device with PCI express Interface is connected to R&S SGU100A PCI express connector
Measurement	Check if external PCI express device can be identified by DUT R&S SGU100A

2 Adjustment

Preliminary Remark

Setting a defined **initial** state by performing the **PRESET** operation prior to adjustments is recommended. In addition, a reliable LO source is required. The adjustments have been optimized for operation with the SGS100A LO source. To ensure that the internal adjustments are valid at operating temperature, at least **30 minutes warm-up time** at this temperature must be observed.

2.1 Procedures after Module Replacement

This chapter describes the necessary measures to restore the performance of the R&S SGU100A after module replacement.

There are no manual adjustments to be performed. Internal adjustment routines are implemented for this purpose. In case external adjustment is required, contact your local Rohde & Schwarz representative.

All spare part boards are tested at Rohde & Schwarz with calibrated working standards according to the performance test. All measurement values are within the specified values including the measurement uncertainty as a minimum guard band.

After replacing an assembly, check the following table to see which service procedure is required.

Changed module	Required action/adjustment/correction	Recommended Test Procedure (refer to chapter 1 " <i>Performance Test</i> ").
Controller Board	SIM card transfer Restore Ethernet MAC Adress (see chapter 2.1.1) Perform Factory Preset (sets instrument default hostname) FW update Setup/Internal Adjustments/Adjust All	Instrument Selftest
Upconverter Mainboard	Setup/Internal Adjustments/Adjust All Absolute Level Correction (external)* Attenuator Correction (external)*	Instrument Selftest Level uncertainty
Doubler Board	Setup/Internal Adjustments/Adjust All Absolute Level Correction (external)* Attenuator Correction (external)*	Instrument Selftest Level uncertainty

Changed module	Required action/adjustment/correction	Recommended Test Procedure (refer to chapter 1 " <i>Performance Test</i> ").
Step Attenuator	Setup/Internal Adjustments/Adjust All Absolute Level Correction (external)* Attenuator Correction (external)*	Instrument Selftest Level uncertainty
Power Supply	Setup/Internal Adjustments/Adjust All	Instrument Selftest
Fan	None	Functional Test
Front panel unit	None	Keyboard Test (see chapter 3.2.3) Functional Test
Internal RF Cables	Setup/Internal Adjustments/Adjust All Absolute Level Correction (external)* Attenuator Correction (external)*	Level uncertainty

* In case external adjustment is required, contact your local Rohde & Schwarz representative.

2.1.1 Restore Ethernet MAC Address

Each SGU100A has a unique, fixed MAC Address to allow the identification in a Ethernet network. The MAC Address is assigned during the instrument production process and must not be changed afterwards.

The SGU100A utilizes the MAC Address that is stored on the Controller Board. A backup of the MAC Address number is stored on the SIM Card. When replacing a Controller Board, the SIM Card has to be transferred to the new Controller Board and the MAC Address number has to be copied from the SIM Card to the new Controller Board using the following procedure:

- Connect the DUT to a PC via USB. Avoid using a LAN connection, because the instrument hostname has changed after replacing the Controller Board. In addition, the network IP-Address may change after the reboot step, if it is set to Auto (DHCP).
- Start the instrument and open a remote control connection.
- Send the command: DIAGnostic:PRODuct:MACaddress:RESTore SIM
- Reboot the DUT and connect with SGMA GUI
- Check the MAC Address under Setup -> Network Settings...
- Compare the MAC-Address to the 12 digit hex number printed on the label on the bottom side of the DUT.

2.2 Adding Hardware Options

This chapter describes the necessary measures to obtain the extended performance of the R&S SGU100A after installing an additional Hardware Option.

Following Hardware Modules are available:

- R&S SGU-B26 Step Attenuator

First install the respective Hardware modules according to the step by step instruction given in chapter 3.

When the hardware installation is fully completed, switch on the instrument and check the detection of the added modules.

- Setup Menu

- Hardware Config... Now the available Hardware is displayed.

To activate the Hardware Option, the appropriate Hardware Option Key must be installed on the instrument SIM Card.

- Setup Menu

- Install Option...

- Option Key: Type the Option Key Number delivered with your HW Option

Restart the instrument and perform the adjustments and tests according to the following table.

Installed module	Required action/adjustment/correction	Recommended Test Procedure (refer to chapter 1 " Performance Test ").
Step Attenuator Option SGU-B26	Setup/Internal Adjustments/Adjust All Absolute Level Correction (external)* Attenuator Correction (external)*	Full performance Test

* In case external adjustment is required, contact your local Rohde & Schwarz representative.

After the external correction procedure, reboot the instrument.

2.3 Internal Adjustments

The internal adjustment routines are controlled by the LO source generator. The adjustments have been optimized for operation with the SGS100A LO source. All internal adjustments are available in the **Setup/Internal Adjustments** menu (see operating manual).

Performing **Setup/Internal Adjustments/Adjust All** activates all internal adjustments in a reasonable order.

2.4 External Adjustments Requiring Measurement Equipment

The external adjustments have to be performed, if the recommended calibration interval is exhausted or RF modules or cables have been replaced.

The external adjustments require calibrated equipment and special software. Data sheet specifications of the unit are concerned. If required, contact your local Rohde & Schwarz representative.

2.5 Internal Self Test

After each module replacement, it is recommended to perform the internal self test (refer to chapter 3, "[Connecting the SGU100A to the SGS100A LO Source](#)"). To allow the integrated operation of the SGU100A / SGS100A combination, first the physical and logical connections between the instruments must be established.

The connection from SGS100A RF output to SGU100A LO input requires a low loss cable. Use the cable included in the Connection Kit R&S SGU-Z4 if possible. The actual cable attenuation is corrected during the internal adjustments procedure.

The baseband signal connection from SGU100A I/Q output to SGS100A I/Q input is only required for I/Q modulation operation at frequencies ≤ 12 GHz. Use the cable included in the Connection Kit R&S SGU-Z4 if possible. The cable attenuation is corrected during the internal adjustments procedure.

The Trigger signal connection from SGS100A TRIG output to SGU100A TRIG input is only required for internal pulse modulation at frequencies $12 \text{ GHz} < f < 20 \text{ GHz}$ (19.5 GHz for instruments with B140/B140V). The cable is included in the Connection Kit R&S SGU-Z4.

The logical connection is achieved by selecting the DUT in the SGS100A connection list. Execute **Extension – Scan** to display the available instruments. Select the wanted SGU100A device. If the instruments are connected by the PCI express cable, the connection is activated automatically.

If the connection fails, check the cabling or use another remote control interface. The instruments can be connected directly by PCI express, USB or LAN interface.

2.5.1 Troubleshooting with Signal Connection Test

The Signal Connection Test checks the LO, I/Q and Trigger rear panel connections between SGS100A LO Source and SGU100A by setting different internal states and measuring internal diagnostic points.

Wire the DUT and the SGS100A LO Source correctly and select the DUT in the SGS100A connection list. Execute **Extension - Test Signal Connections - Test**. The test generates a pictogram showing the available connections:

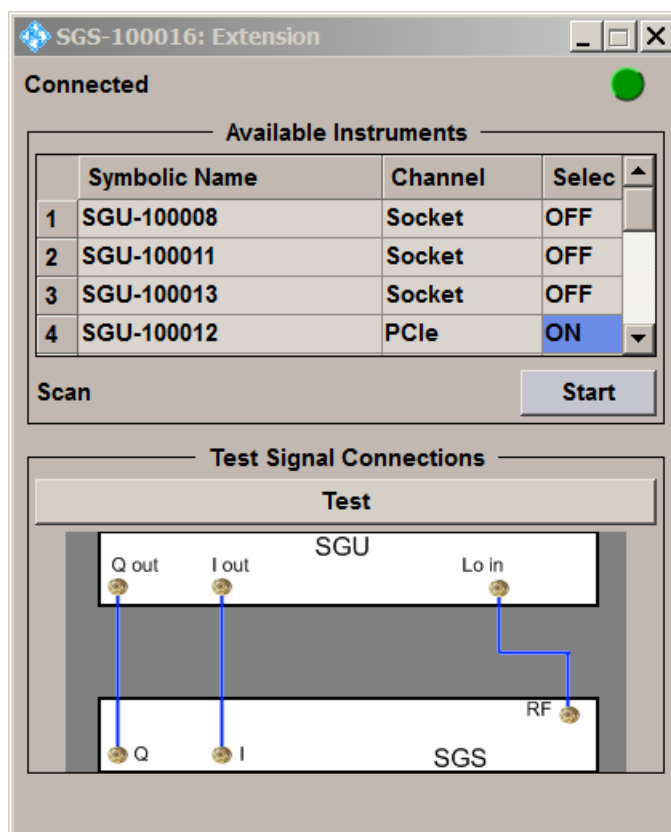

Troubleshooting with Internal Selftest[®].

The self test checks the instrument by measuring internal diagnostic points and verifies whether the generator is operating properly. The self test procedure is controlled by the LO source.

If a self test failure occurs, check again whether all cables are properly connected. If the self test fails continuously, contact your local service center.

3 Repair

A schematic of the signal generator's design is presented below as block diagram at module level (see also block diagram in the appendix).

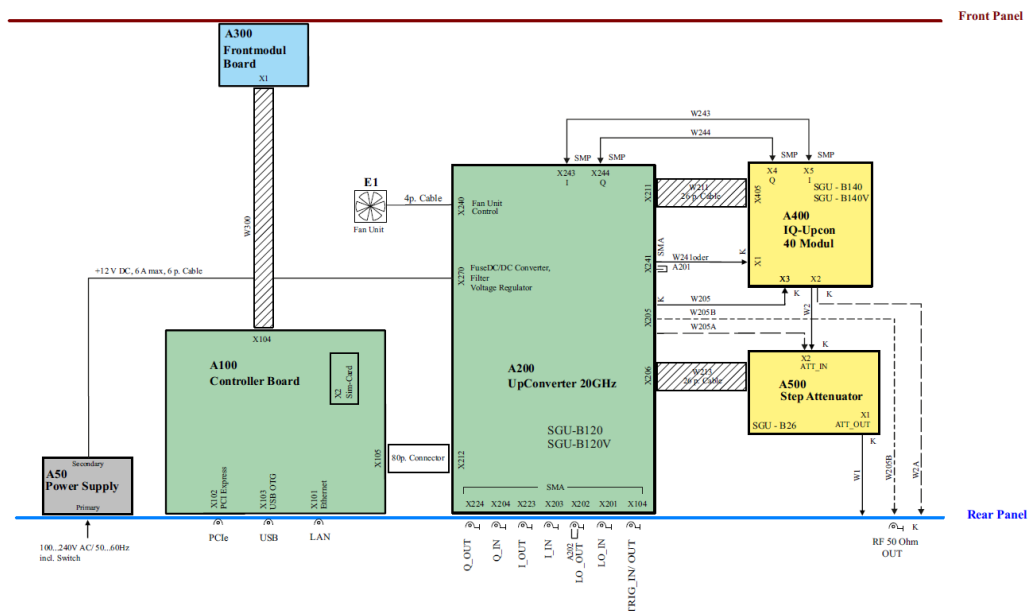

The R&S SGU100A consists of very few main modules and very few connections between these modules. The main units are:

- Power Supply
- Controller Board which includes all digital external interfaces, the main CPU, the hardware drivers for the front panel and the Interface to the Upconverter Mainboard.
- Front Unit consisting of the front module board with keys and LED indicators
- Upconverter Mainboard containing the basic RF functionality, the instrument analog and RF connectors and interfaces to all other modules and HW options.
- Doubler Board (Option R&S SGU-B140 or R&S SGU-B140V) containing RF circuitry to extend the frequency range.
- Step Attenuator (Option R&S SGU-B26) containing RF circuitry to extend the level dynamic range.
- Fan Unit for forced cooling of the instrument modules

A detailed description of these modules is given in section "[Functional Description](#)" on page 45.

3.1 Functional Description

3.1.1 Power Supply Module

The power supply module provides a single 12 V supply voltage for the operation of the signal generator. It can be switched on and off by means of the power switch on the rear panel.

The power supply works over a wide input voltage range from 100 V to 240 V ($\pm 10\%$) and AC supply frequencies from 50 Hz to 60 Hz ($\pm 5\%$). The power factor correction meets EN 61000-3-2.

The secondary voltage is open-circuit-proof and short-circuit-proof.

The primary fuses are located inside the power supply module and cannot be replaced.

Further fuses are fitted on the Upconverter Mainboard as a means of fire protection.

3.1.2 Controller Board

The Controller Board of the signal generator involves the following components and modules:

3.1.2.1 Switching regulators

Switching regulators for 1.0 V, 1.2 V, 1.8 V and 3.3 V controller supply voltages.

3.1.2.2 Controller

Central Controller of the R&S SGU100A including all memory devices and external interfaces.

3.1.2.3 FPGA

Performs data processing for the serial buses, which send setting data to the modules. It also contains the controllers for the SmartCard, the Keyboard and LEDs. The FPGA is configured via an SPI-Interface of the processor.

3.1.2.4 Diagnostic Multiplexer

The diagnostic Multiplexer is used for measuring the supply voltages of the Controller Board during failure diagnostic.

3.1.2.5 EEPROM

Contains identification data of the board.

3.1.2.6 Temperature sensor

A temperature sensor mounted on the Controller Board monitors the temperature. If a defined temperature above the guaranteed maximum operating temperature is exceeded, the modules in the instrument are switched off. So the R&S SGU100A secures itself against damage due to overheating.

3.1.3 Upconverter Mainboard

The Upconverter Mainboard contains the basic analogue hardware of the instrument. The RF output signal is generated by frequency multiplication of the LO input signal. Analogue IQ modulation can be performed when the vector modulation option is equipped. The output level is set by a level control loop. The RF output of the Upconverter Mainboard drives the instrument output or the optional step attenuator. The Upconverter Mainboard is controlled by the Controller Board via a serial bus and additional control signals.

3.1.3.1 Block diagram

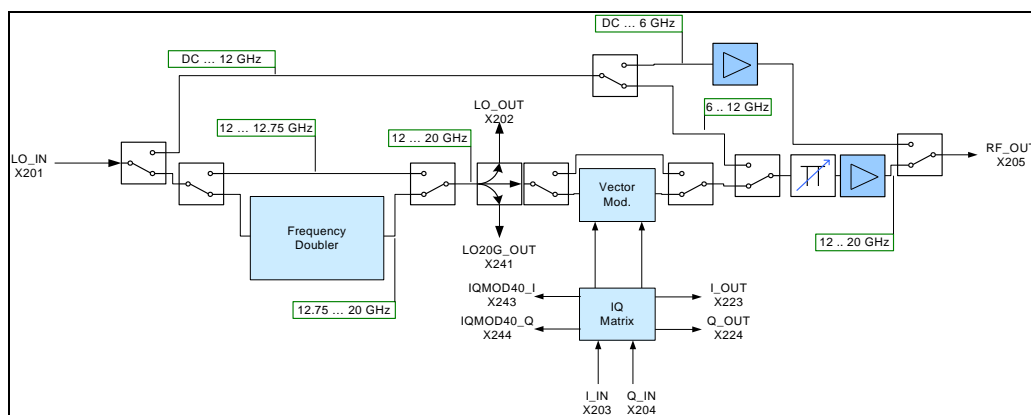

3.1.3.2 Implemented functions

- Frequency doubler with bypass path
- Vector modulator (Option)
- Phase coherent output
- Harmonics filter
- RF amplifiers
- Level control
- Diagnostics
- Power supply for optional RF modules
- Control interface for optional RF modules

3.1.3.3 Frequency doubler

The RF input stage of the SGU100A delivers a LO signal in the frequency range from 12 GHz to 20 GHz to the following RF stages. For RF output frequencies above 12.75 GHz, the LO signal is doubled in frequency. The frequency doubler is bypassed for RF output frequencies up to 12.75 GHz.

The output signal of the doubler / bypass stage is available on the LO OUT connector.

3.1.3.4 Vector modulator

The doubler / bypass stage signal can be routed directly to the following RF chain or the optional vector modulator, which can multiply the signal by the external analog I/Q signals. The modulator device is placed only on the vector version of the Upconverter Mainboard (1418.2657.01).

3.1.3.5 Automatic Level control

With the means of a directional coupler a small part of the output signal of the power amplifier is fed to an RF detector. The output signal of this RF detector is fed to the Automatic Level Control (ALC) unit. The ALC sets the Level Control Voltage controlling the variable attenuators to reach the desired output level.

3.1.3.6 Fan Controller

The fan for cooling the RF modules is connected to the Upconverter Mainboard and controlled according to the temperature of the Upconverter Mainboard.

3.1.3.7 Supply voltage control and filtering

The supply voltages required for the Upconverter Mainboard and the optional HW modules are generated by switched mode converters and filtered by means of passive filtering and additional active voltage regulators.

3.1.4 Doubler Board

3.1.4.1 Doubler Board architecture

The option incorporates a frequency doubler from 9.75 ... 20 GHz to 19.5 ... 40 GHz and means for amplification and level control for the frequency range from 19.5 GHz ... 40 GHz. Alternatively, signals in the frequency range from 10 MHz to 19.5 GHz can be routed through a second passive signal path directly to the module RF output.

The Doubler Board is inserted between Upconverter Mainboard and optional Step Attenuator such that the frequency range of the combination extends to 40 GHz in CW mode as well as in vector modulated mode. The doubler board consists of a microwave module and a control PCB including an Eeprom to store specific data, temperature sensors and a diagnosis system. Control and power supply is provided by the Upconverter Mainboard.

Note: Each Doubler board PCB contains individual factory adjustment data that is only valid for the respective microwave module. Do not disassemble the PCB / microwave module combination.

3.1.4.2 Doubler Board diagram

The following diagram shows the RF-chain of the Doubler Board consisting of a doubler, a filter bank, a local oscillator amplifier, a quadrature modulator, a power amplifier and an output switch for band selection.

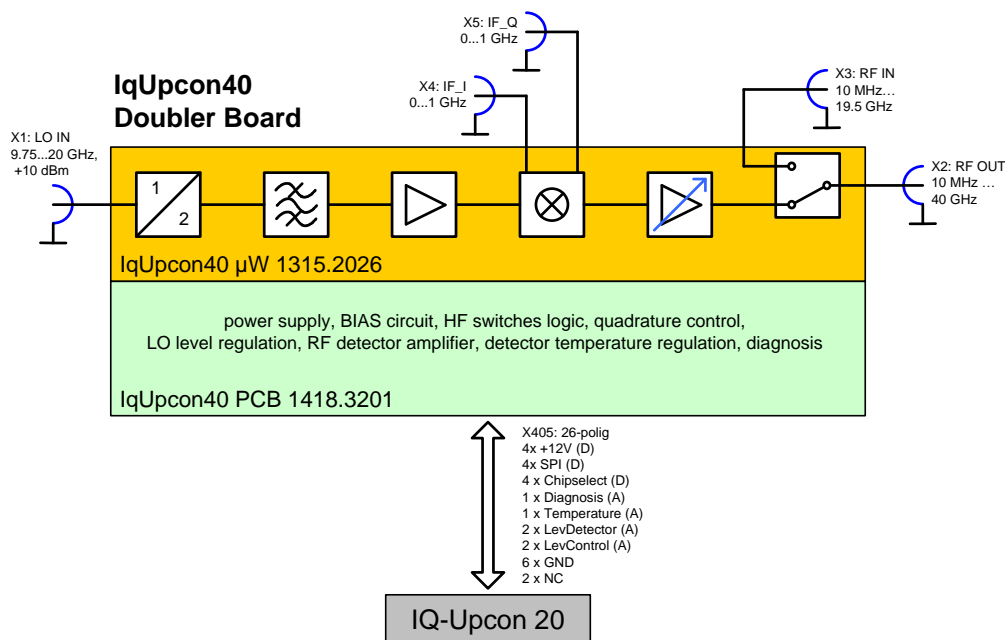

Figure 3-1: Doubler Board diagram

3.1.5 Step Attenuator

3.1.5.1 Step Attenuator architecture

The dynamic range of the electronic level control system is limited due to several technical restrictions. To extend the dynamic range, a variable attenuator with high dynamic range is required at the output of the instrument. The attenuation can be switched in 5 dB steps from -115 dB to 0 dB nominal. To minimize the attenuator loss, the attenuator is based on high performance mechanical switches. The module includes an Eeprom to store specific data, a temperature sensor and a diagnosis system. Control and power supply is provided by the Upconverter Mainboard.

3.1.5.2 Step Attenuator diagram

The following diagram shows the functional equivalent of the module:

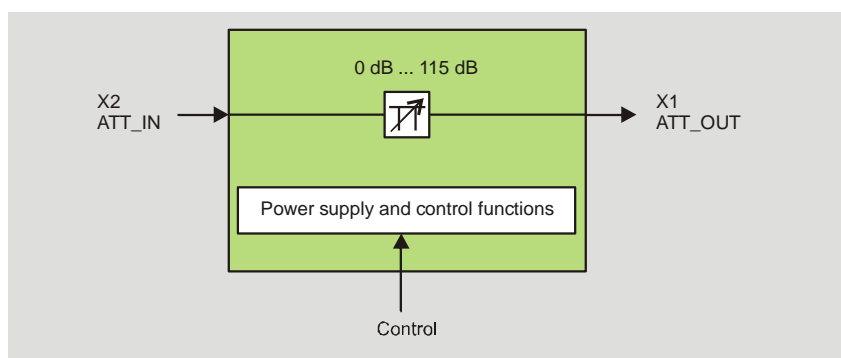

Figure 3-2: Step Attenuator diagram

3.2 Troubleshooting

The purpose of these troubleshooting instructions is to help to trace down malfunctions to board level. The instrument can thus be made ready for use again by means of board replacement.

If error tracing doesn't show clear results, we recommend that you ship your instrument to our experts in the service centers (see address list) for module replacement and further error elimination. Some module replacements involve calibration procedures requiring calibrated equipment and appropriate software.

WARNING

Danger of shock hazard

For module replacement, ensure that the instrument is switched off and disconnected from the power supply by removing the plug from the AC and DC power connector.

Read all safety instructions at the beginning of this manual carefully before module replacement!

NOTICE

Risk of damage to the boards

Be careful not to cause short circuits when measuring voltages at pins placed close together!

The following utilities are provided in the signal generator for easy diagnosis and can be controlled by the R&S SGMA GUI software:

- Internal self test
- Internal diagnosis test points
- Internal adjustments
- Info line with error messages and history of messages displayed in R&S SGMA GUI software

Note: *When problems occur, first check whether any connections (cables, plug-in connections of boards, etc.) are damaged or wrongly connected.*

3.2.1 Measuring Equipment and Accessories

Item	Type of equipment	Specifications recommended	Equipment recommended	R&S order No.
1	Multimeter		-	
2	Spectrum analyzer	Frequency range 0 to 40 GHz	R&S FSQ40 or similar	1155.5001.40
3	Oscilloscope	Bandwidth \geq 500 MHz	R&S RTM1052 or similar	1305.0008.52

3.2.2 Switch-On Problems

After switching on the AC power supply via the switch on the back of the instrument, the following steps happen during the boot process:

Step	Visible Effect	Operational Requirements
1	Green power LED lights up without flashing	<ul style="list-style-type: none"> ➤ AC Power supply ok, ➤ 12 V Fuse on Upconverter Mainboard ok, ➤ Connection from Upconverter Mainboard to Controller Board ok, ➤ 1.0 V and 3.3 V switching regulator on Controller Board ok, ➤ Connection of Front Module Board to Controller Board ok.
2	After 1 second: Green power LED starts flashing, LED on Controller Board lights up.	<ul style="list-style-type: none"> ➤ Controller operational and starts booting, ➤ Successful loading of FPGA configuration.
3	After 40 seconds: Green power LED again lit steadily	<ul style="list-style-type: none"> ➤ Firmware installation intact ➤ Booting successful
4	Device can be accessed from SGMA-Gui via any of the remote control ports.	<ul style="list-style-type: none"> ➤ Used port intact and operational

- **Error: boot process step 1 not reached**

Action	Possible error causes and further steps
Check voltage on power supply module output (12.0 V ... 12.3 V). ↓	Short circuit on secondary side. Disconnect power supply module from Upconverter Mainboard and recheck voltage on power supply module. If it still does not match the rated value, replace power supply module. If voltage is correct now, reconnect boards and fan one by one and search this way for the module, which causes the short circuit.
Check Fuses on Upconverter Mainboard. ↓	If fuses are blown, proceed as described in section " Fuses " on page 63.
Check 12 V supply voltage on Controller Board ↓	Either Controller Board or Upconverter Mainboard is defect.
Check 1.0 V (0.95 V...1.05 V) and 3.3 V (3.15 V...3.45 V) supply voltages on Controller Board. ↓	If voltages do not match the rated value, replace Controller Board.
Check green LED on Controller Board	If LED is lit, then Front Module Board is defect or not connected properly to Controller Board.

3.2.2.1 Test Points on Controller Board

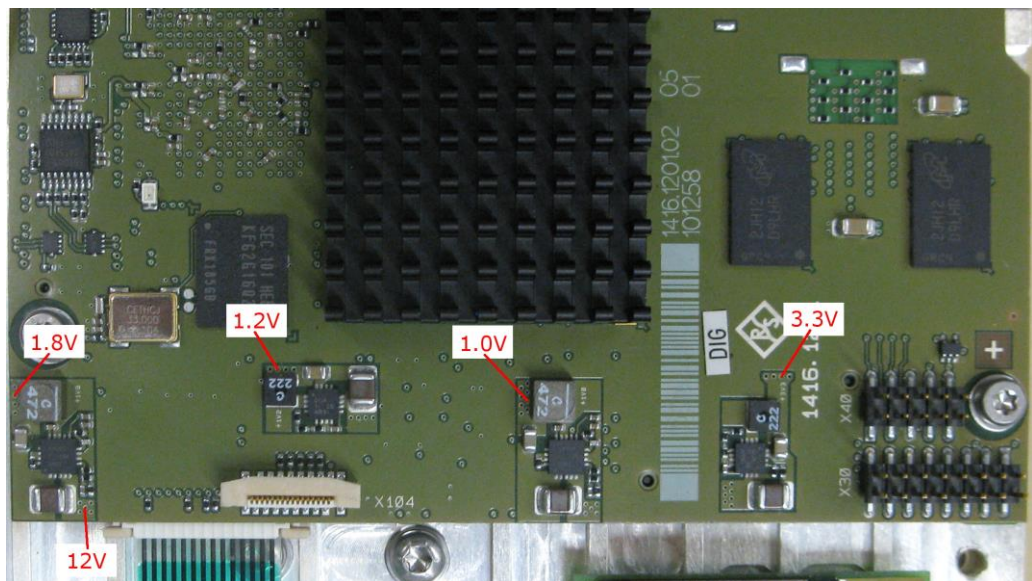

Note: The screws of the Upconverter Mainboard shield may be used as ground potential for the measurements.

- **Error: boot process step 2 or 3 not reached**

Action	Possible error causes and further steps
Try to reinstall Firmware via Recovery System.	If not possible, replace Controller Board.

- **Error: boot process step 4 not reached**

Action	Possible error causes and further steps
Try different remote control port (USB, Ethernet, PCI Express).	If only one port is not working, check your cabling and look out for LAN related problems. If no other reason is found, replace Controller Board.

3.2.3 Keyboard and LED Test

- This **utility** allows you to check for proper operation of all front panel elements

Normal action	Error, possible causes and corrective action
<p>Test called by SGMA-GUI (SGU) with Diagnostic/Test - Keyboard Test - On</p> <p>or by SGU remote command :TEST:KEYBoard[:STATe] ON</p> <p>All LEDs except the Power/Standby indicator change to orange.</p>	<p>If the LEDs except the Power/Standby indicator do not light in orange color, the front panel is defective. Change the front panel.</p>
<p>Pressing the keys in the order RF ON – LAN - ID changes the color of all LEDs except the Power/Standby indicator simultaneously to Red – Off -Green.</p>	<p>If the color does not change according to the description, a malfunction has occurred.</p> <p>If the color remains unchanged after actuation, the key is defective.</p> <p>In either case: Change the front panel.</p>
<p>Exit the test mode by SGMA-GUI with Diagnostic/Test - Keyboard Test - Off</p> <p>or by remote command :TEST:KEYBoard[:STATe] OFF</p>	<hr/> <p>Note: <i>The test can not output internally generated pass/fail information. The user must decide whether a malfunction has occurred.</i></p> <hr/>

3.2.4 USB Cable Test

USB cables of good quality are required for EMI suppression and stable connections. However, according to our experience USB cables are of varying and often poor quality. This concerns the connection between the cable shield and the shield contacts of the connectors.

Cables of poor quality may cause EMI interference and poor connection quality. EMI interference, among other things, may ultimately lead to measurement errors. Poor connection quality may create problems like increased latencies that are due to retransmissions because of data corruption or may even lead to a complete loss of data connection.

Therefore, we recommend checking every USB cable using the following easy method:

Measure the electrical resistance from the shield contact of one connector to the shield contact of the other connector. For correct measurement results, consider the contact resistance at your probe tips. Good cables have a value of less than 0.6 Ω according to USB standards.

Also check, whether the resistance is stable when you bend the cable.

3.2.5 Connecting the SGU100A to the SGS100A LO Source

To allow the integrated operation of the SGU100A / SGS100A combination, first the physical and logical connections between the instruments must be established.

The connection from SGS100A RF output to SGU100A LO input requires a low loss cable. Use the cable included in the Connection Kit R&S SGU-Z4 if possible. The actual cable attenuation is corrected during the internal adjustments procedure.

The baseband signal connection from SGU100A I/Q output to SGS100A I/Q input is only required for I/Q modulation operation at frequencies ≤ 12 GHz. Use the cable included in the Connection Kit R&S SGU-Z4 if possible. The cable attenuation is corrected during the internal adjustments procedure.

The Trigger signal connection from SGS100A TRIG output to SGU100A TRIG input is only required for internal pulse modulation at frequencies $12 \text{ GHz} < f < 20 \text{ GHz}$ (19.5 GHz for instruments with B140/B140V). The cable is included in the Connection Kit R&S SGU-Z4.

The logical connection is achieved by selecting the DUT in the SGS100A connection list. Execute **Extension – Scan** to display the available instruments. Select the wanted SGU100A device. If the instruments are connected by the PCI express cable, the connection is activated automatically.

If the connection fails, check the cabling or use another remote control interface. The instruments can be connected directly by PCI express, USB or LAN interface.

3.2.6 Troubleshooting with Signal Connection Test

The Signal Connection Test checks the LO, I/Q and Trigger rear panel connections between SGS100A LO Source and SGU100A by setting different internal states and measuring internal diagnostic points.

Wire the DUT and the SGS100A LO Source correctly and select the DUT in the SGS100A connection list. Execute **Extension - Test Signal Connections - Test**. The test generates a pictogram showing the available connections:

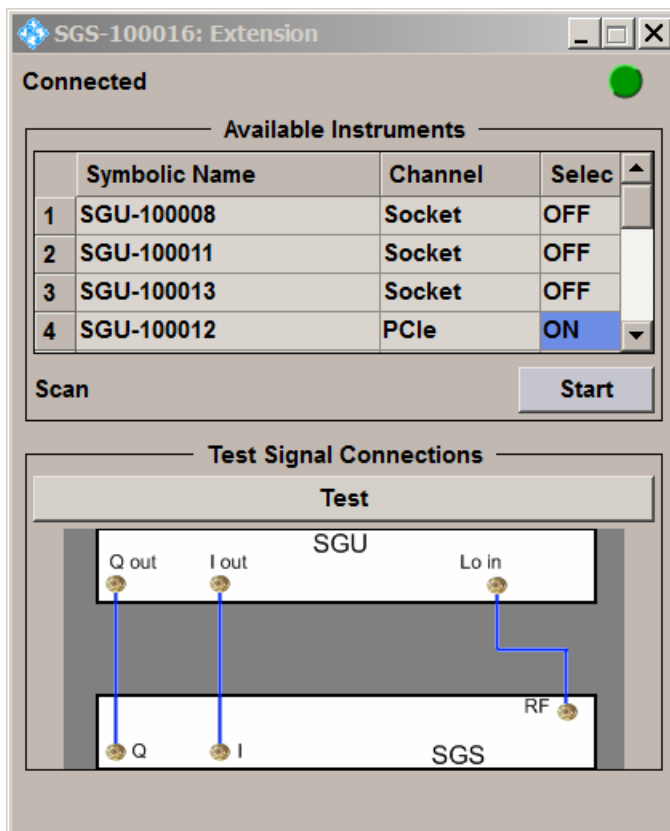

3.2.7 Troubleshooting with Internal Selftest

The internal self test checks the instrument by setting different internal states and measuring internal diagnostic points.

In the LO source instrument, execute **Diagnostic/Test – Selftest - Start Selftest**. The self test reports the modules in LO source and SGU100A failing the test:

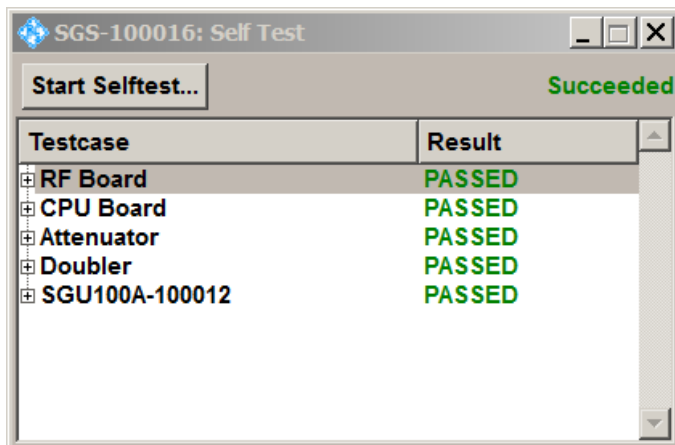

To see the details of the self test open the corresponding branch of the result tree:

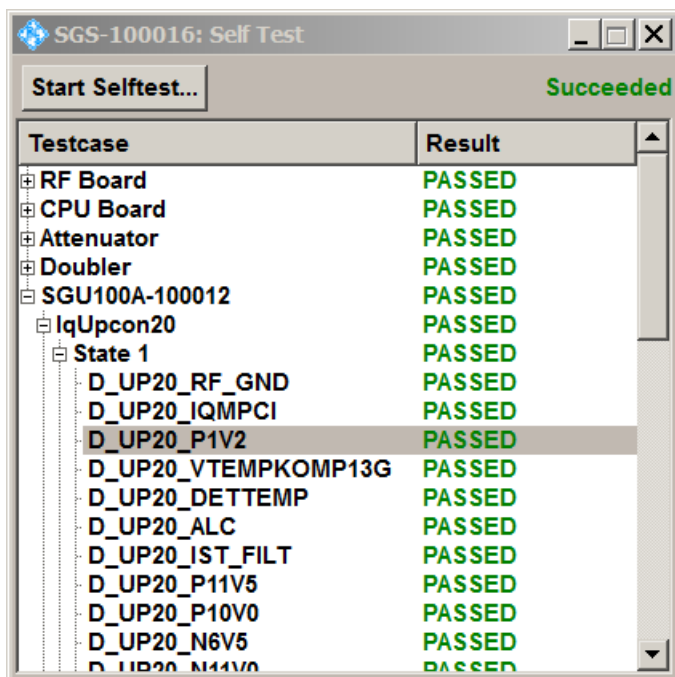

3.2.8 Troubleshooting with Internal Adjustments

Various internal adjustments are necessary for correct operation of the instrument. The failure of a certain adjustment can shorten troubleshooting considerably. The affected module is the Upconverter Mainboard and the installed R&S SGU-B140 Doubler Board.

All internal adjustments are started and controlled from the LO source generator.

Note: Failed internal adjustments can also be queried on the info page -> History.

Normal action	Error, possible causes and corrective action
<p>Internal adjustments call at LO source: Setup - Internal Adjustments - Adjust All Internal adjustment of the LO source, the connected Upconverter Mainboard and the optional R&S SGU-B140/-B140V Doubler Board is executed.</p> <p>If checkbox 'extension only' is activated, only the Internal Adjustments related to the SGU are performed.</p>	<p>Abort during adjustment:</p> <p>The synthesis, level and vector modulator adjustments of the LO source generator are carried out exclusively on the LO source instrument. In addition, the SGU100A modules are tested using the Diagnostic A/D converter on the Upconverter Mainboard.</p> <p>If an adjustment fails the error reporting system might give a hint pointing to the defective module. Check the connections LO Source – SGU100A (see page 56).</p> <p>Perform the instrument self test (see page 42).</p>

3.2.9 Instrument Faults

The following table lists some instrument faults. For every fault additional test are described to determine the defective module.

Fault	Test	Action if test fails
RF Output Level is wrong	LO source settings: <ul style="list-style-type: none"> • Instrument Preset • Reference Oscillator → Source Int • RF on • Mod off • Level = 0 dBm Measure the SGU100A output Level with a power meter across the frequency range. The difference between set and measured level has to be lower than guaranteed in the datasheet.	Perform all internal adjustments. Check the connections LO Source – SGU100A. If the level error remains, most probably a RF module is defective or an external level correction is required. Instrument without step attenuator: Most probably the Upconverter Mainboard is defective. Check the Upconverter Mainboard being supplied correct (see page 63). Instrument with step attenuator option: Most probably the Upconverter Mainboard or the Step Attenuator is defective. Check the Upconverter Mainboard being supplied correct (see page 63).

Fault	Test	Action if test fails
RF Output Frequency is wrong	LO source settings: <ul style="list-style-type: none"> • Instrument Preset • Setup ➔ Internal Adjustment ➔ 'Adjust all' • Reference Oscillator ➔ Source Ext • Reference Oscillator ➔ Ext Ref Input Frequency 10 MHz • RF on • Mod off • Level: 0 dBm • Frequency = 1 GHz Supply an external 10 MHz reference signal meeting the level and frequency specification given in the datasheet. Measure output frequency with a spectrum analyzer or a frequency counter synchronized to the same reference. The frequency error has to be < 0.1 Hz.	Check the connections LO Source – SGU100A. Most probably the LO Source is defective. Check the LO Source operation.

Fault	Test	Action if test fails
Slow Settling times	Settling times are defined for PCI express remote control only. The settling time is the time-delay after the remote control command arrives at the R&S SGS100A until level and frequency are within the given tolerance from their final values. Be careful not to measure with an instrument drifting on its own due to applying the RF from the R&S SGU100A.	Check the connections LO Source – SGU100A. Check if the Slow Setting time is caused by the remote control system or the SGS LO source. Otherwise, most probably the Upconverter Mainboard is defective. Check the Upconverter Mainboard being supplied correct (see page 63).

Fault	Test	Action if test fails
LO Input faulty	<p>LO source settings (Extension disconnected):</p> <ul style="list-style-type: none"> • Instrument Preset • Setup ➔ Internal Adjustment ➔ 'Adjust all' • Reference Oscillator ➔ Source Int • RF on • Mod off • Level: 10 dBm • Frequency = 7.5 GHz <p>Check the LO signal with a spectrum analyzer and power meter. If level and frequency of this signal is matching the specification, connect the LO signal to the R&S SGU100A.</p> <p>Set the SGU100A to:</p> <ul style="list-style-type: none"> • Instrument Preset • RF on • Mod off • Frequency = 15 GHz • Level = 0 dBm <p>Check for error Messages. No errors concerning the RF input signal are allowed to occur.</p>	<p>Check the connections LO Source – SGU100A.</p> <p>Most probably the LO signal connection is faulty or too lossy. Use short precision cables with low attenuation (< 2 dB) to connect the LO source to the SGU100A RF input.</p>

Fault	Test	Action if test fails
I/Q ext Input Faulty	<p>LO source settings:</p> <ul style="list-style-type: none"> • Instrument Preset • Reference Oscillator ➔ Source Int • Frequency = 15 GHz • RF on • Mod on <p>Measure the input resistance of the I/Q Input SMA connector with a multimeter. The input resistance should be $50 \Omega \pm 10 \%$.</p>	<p>Most probably the Upconverter Mainboard is defective. Check the Upconverter Mainboard being supplied correct (see page 63).</p>

Fault	Test	Action if test fails
Vector Modulation faulty	<p>The vector modulation performance is specified only up to the Peak Envelope Power (PEP) noted in the datasheet. Ensure the internal IQ adjustment was performed successfully.</p> <p>The vector modulation performance has to match the values given in the datasheet. Measure with a vector signal analyzer with sufficient performance, i.e. an R&S FSQ or R&S FSW spectrum analyzer.</p>	<p>Check the connections LO Source – SGU100A.</p> <p>Check the Upconverter Mainboard being supplied correct (see page 63).</p> <p>If the problem occurs at frequencies lower than 12 GHz, check the SGS100A LO Source.</p> <p>If the problem occurs at frequencies between 12 GHz and 19.5 GHz, the Upconverter Mainboard might be defective.</p> <p>If the problem occurs at frequencies above 20 GHz, the Doubler Board might be defective.</p>

Fault	Test	Action if test fails
Trigger Input / Output faulty	This signal is driven from the Upconverter Mainboard FPGA. The Trigger Input / Output SMA connector is directly fitted onto the Upconverter Mainboard.	Most probably the Upconverter Mainboard is defective. Check the Upconverter Mainboard being supplied correct (see page 63).

Fault	Test	Action if test fails
Faulty Remote interface PCI express, USB or LAN	All remote interfaces including the interface connectors are fitted directly on the Controller Board.	Most probably the Controller Board is defective. Check the Controller Board being supplied correct (see section " Switch-On Problems " on page 51).

Fault	Test	Action if test fails
Instrument switches off, error message "Emergency shutdown" appears	<p>Check if fan operates during instrument boot procedure.</p> <p>Check if fan operation is constrained by dust etc.</p>	<p>Remove and clean the fan unit.</p> <p>If necessary, replace the fan (see page 90).</p>
	Check ambient temperature.	Ensure proper cooling of the instrument and do not limit the air flow. Operate the instrument inside the ambient temperature specifications.

3.2.9.1 Fuses

Switch on the R&S SGU100A and measure the voltage at fuse F2800.2. If the Voltage is less than 12 V, change the power supply.

If the voltage is o.k., measure the voltage at fuse F2800.1. If the voltage is much lower than 11.9 V, then fuse F2800 is blown and most probably the Controller Board (1416.1201) is faulty. Replace the fuse with the correct type given by the table below and check the Controller Board (see section "[Switch-On Problems](#)" on page 51).

Measure the voltage at fuse F1.1. If the voltage is much lower than 11.9 V, then fuse F1 is blown. The fuse might be blown due to a defective module other than the Upconverter Mainboard. If the fuse is blown, replace the fuse with the correct type given below. Remove the connections to the Doubler Board (X211) and the step attenuator (X206), if present. Switch on the R&S SGU100A and after two minutes check the voltage drop across fuse F1 again. If the fuse is blown again, the Upconverter Mainboard is defective and should be replaced.

If the fuse is o.k., switch off the R&S SGU100A again. If the R&S SGU100A is equipped with step attenuator, then connect the step attenuator. Switch on the R&S SGU100A again. If the fuse is blown after two minutes, the step attenuator module is defective and has to be replaced (see page 94).

If the R&S SGU100A is equipped with a Doubler Board, switch off the R&S SGU100A and connect this module to the Upconverter Mainboard (X211). Switch on the R&S SGU100A again. If the fuse is blown after two minutes, the Doubler Board is faulty and has to be replaced (see page 91).

After replacement of defective modules don't forget to replace fuse F2800 and/or F1 too!

Module	Fuse	Type	R&S Part Number	Manufacturer Part Number
Upconverter Mainboard	F1	FF7A	2079.5994.00	Littlefuse R451.007 NRL (MRL)
Upconverter Mainboard	F2800	FF7A	2079.5994.00	Littlefuse R451.007 NRL (MRL)

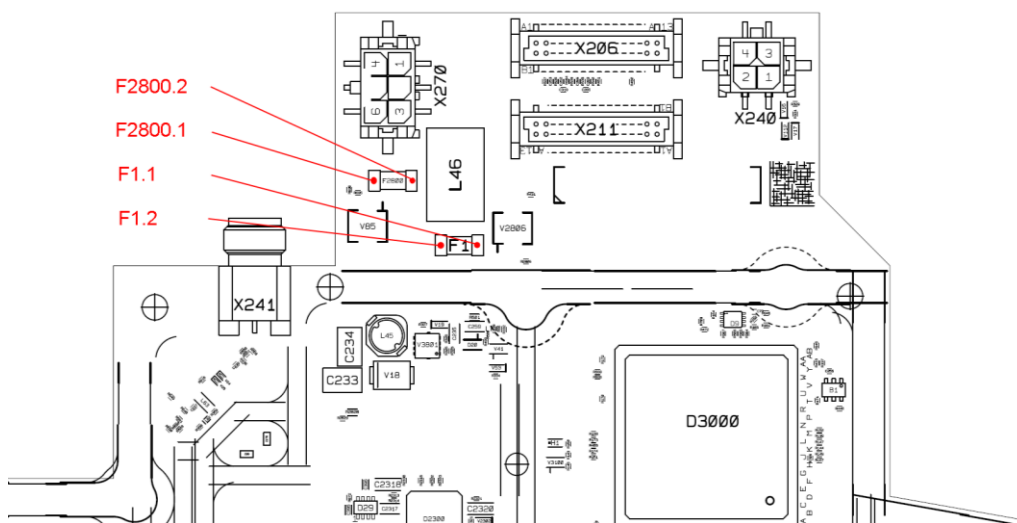

Figure 3-3: Position of the fuses on the Upconverter Mainboard

3.2.10 Troubleshooting – Upconverter Mainboard

The tests listed below ensure that an assumed error on the Upconverter Mainboard is not caused by a defective or incorrectly connected cable, incorrect adjustment or another module.

3.2.10.1 Internal Adjustment “Adjust All”

A comprehensive test of the module is to run the internal adjustment.

Normal action	Error, possible causes and corrective action
Internal adjustments call: Setup – Internal Adjustments... - Adjust Synthesis Internal adjustment of the synthesizer on the LO source is executed. As result “Pass” is displayed.	Abort during adjustment: The adjustments are all carried out exclusively on the LO source. Most probably the LO source is defective. Check the LO source generator.
Internal adjustments call: Setup – Internal Adjustments... - Adjust Level Internal adjustment of the ALC Loop on the Upconverter Mainboard is executed. As result “Pass” is displayed.	Abort during adjustment: If the adjustment fails even with disconnected Doubler Board, most probably the Upconverter Mainboard is faulty. When the adjustment fails only with Doubler Board, the Doubler Board may be defective.
Internal adjustments call: Setup – Internal Adjustments... - Adjust IQ Modulator Internal adjustment of the IQ-Modulator on the Upconverter Mainboard is executed. As result “Pass” is displayed	Abort during adjustment: The adjustments are all carried out exclusively on the Upconverter Mainboard. Most probably the Upconverter Mainboard is defective. Check the board being supplied correctly (see page 64).

3.2.10.2 Input and Output Signals

Connector, system	Signal name	Setting on signal generator	Frequency	Level	Signal flow
X205, PC2.9	RF_OUT	RF on	10 to 40000 MHz	-120 to +25 dBm	To RF connector at rear panel or step attenuator
X201, SMA	LO_IN	---	10 to 12750 MHz	up to 25 dBm in bypass mode 7 to 13 dBm otherwise	LO-Input
X202, SMA	LO_OUT	---	12 to 20 GHz	7 to 13 dBm	LO-Output
X203, SMA	I_IN	IQ-Modulation activated	0 to 1000 MHz	-0.5 to +0.5 V	I-Input for Vector Modulation
X204, SMA	Q_IN	IQ-Modulation activated	0 to 1000 MHz	-0.5 to +0.5 V	Q-Input for Vector Modulation
X223, SMA	I_OUT	RF Frequency < 12 GHz	0 to 1000 MHz	-0.5 to +0.5 V	To I_IN of LO generator
X224, SMA	Q_OUT	RF Frequency < 12 GHz	0 to 1000 MHz	-0.5 to +0.5 V	To Q_IN of LO generator
X241, SMA	LO20G_OUT	RF Frequency > 20 GHz	10 to 20 GHz	-3 to -12 dBm	To doubler board
X104, SMA	TRIG	---	---	LVC logic	Bidirectional trigger input/output

See also [Figure 3-4: Connectors](#).

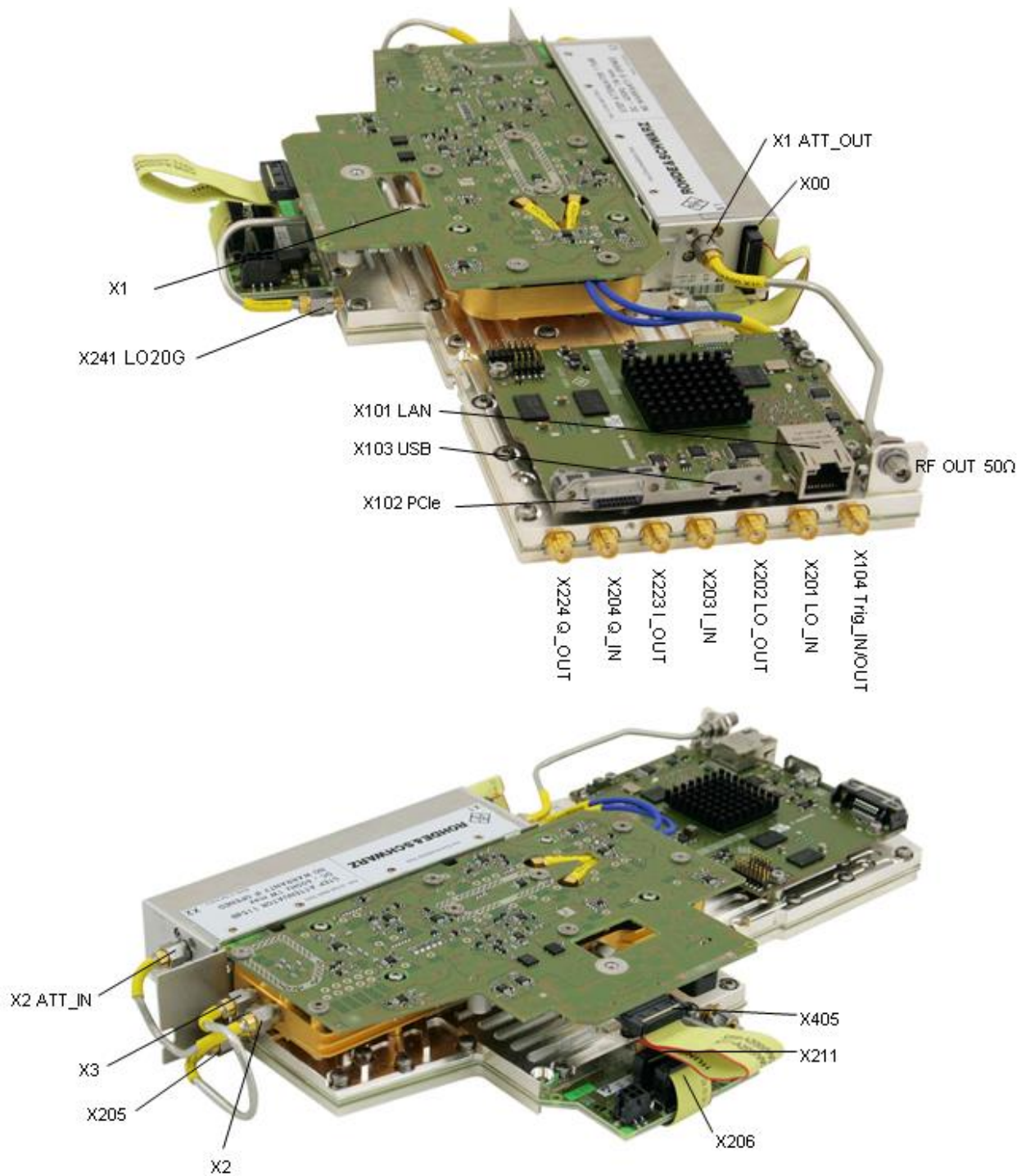

Figure 3-4: Connectors

3.2.10.3 Error Messages Concerning the Upconverter Mainboard

Error message	Error correction
"I/Q-Input protection tripped, RF switched off!"	<ul style="list-style-type: none"> ➤ Check if connected IQ-Source Level is exceeding limits
"Local oscillator input power too low."	<ul style="list-style-type: none"> ➤ Check cabling to LO generator for correctness and damages ➤ Check output power of LO generator ➤ If the error message does not disappear change the module.
"Local oscillator input-power too high - reduce or disconnect to prevent damage."	<ul style="list-style-type: none"> ➤ The incoming power from the LO generator is to high. ➤ Check power of LO-generator ➤ If the error message does not disappear change the module.
"Pep value exceeds allowed limit."	<ul style="list-style-type: none"> ➤ The peak envelope power (PEP) is higher than the allowed limit. ➤ Reduce the output level.
"Fan speed too low"	<ul style="list-style-type: none"> ➤ Check fan for clogging
"Questionable IQ adjustment data"	<ul style="list-style-type: none"> ➤ Run IQ adjustment

3.2.10.4 Warnings Concerning the Upconverter Mainboard

Warnings	Warning correction
"Pep value exceeds defined limit"	<ul style="list-style-type: none"> ➤ The peak envelope power (PEP) is higher than the set upper limit. ➤ Reduce the output level.

3.2.11 Troubleshooting – Step Attenuator

3.2.11.1 Supply Voltages

The step attenuator supply voltages can be tested by starting the instrument selftest.

By changing the instrument level across the attenuator switching threshold levels, the operation can be noticed by the noise of the mechanical switches.

To verify the attenuation, the attenuator module can be operated externally to the SGU100A and measured with external measurement equipment.

3.2.12 Troubleshooting – Doubler Board opt. R&S SGU-B140/-B140V

3.2.12.1 Supply Voltages

Check the internal supply voltages of the Doubler Board with the internal diagnosis described in section "[Connecting the SGU100A to the SGS100A LO Source](#)"

To allow the integrated operation of the SGU100A / SGS100A combination, first the physical and logical connections between the instruments must be established.

The connection from SGS100A RF output to SGU100A LO input requires a low loss cable. Use the cable included in the Connection Kit R&S SGU-Z4 if possible. The actual cable attenuation is corrected during the internal adjustments procedure.

The baseband signal connection from SGU100A I/Q output to SGS100A I/Q input is only required for I/Q modulation operation at frequencies ≤ 12 GHz. Use the cable included in the Connection Kit R&S SGU-Z4 if possible. The cable attenuation is corrected during the internal adjustments procedure.

The Trigger signal connection from SGS100A TRIG output to SGU100A TRIG input is only required for internal pulse modulation at frequencies $12 \text{ GHz} < f < 20 \text{ GHz}$ (19.5 GHz for instruments with B140/B140V). The cable is included in the Connection Kit R&S SGU-Z4.

The logical connection is achieved by selecting the DUT in the SGS100A connection list. Execute **Extension – Scan** to display the available instruments. Select the wanted SGU100A device. If the instruments are connected by the PCI express cable, the connection is activated automatically.

If the connection fails, check the cabling or use another remote control interface. The instruments can be connected directly by PCI express, USB or LAN interface.

3.2.13 Troubleshooting with Signal Connection Test

The Signal Connection Test checks the LO, I/Q and Trigger rear panel connections between SGS100A LO Source and SGU100A by setting different internal states and measuring internal diagnostic points.

Wire the DUT and the SGS100A LO Source correctly and select the DUT in the SGS100A connection list. Execute **Extension - Test Signal Connections - Test**. The test generates a pictogram showing the available connections:

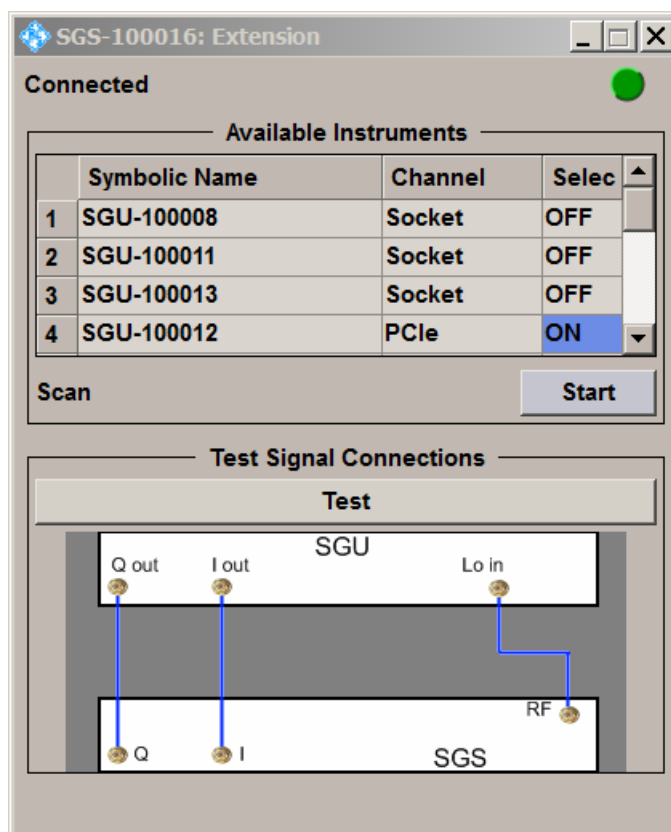

Troubleshooting with Internal Selftest" (diagnosis test points: D_UP40_P5VREF, D_UP40_P2V5, D_UP40_P3V3, D_UP40_P4V8, D_UP40_P5V1, D_UP40_P5V3, D_UP40_P6V0, D_UP40_P10V0, D_UP40_P12V0, D_UP40_P19V0, D_UP40_P22V0, D_UP40_N2V5, D_UP40_N10V0, D_UP40_N12V0, D_UP40_N18V0).

If one or more tests fail, remove the case (see page 75) and the EMC panel (see page 75), and check the 12 V supply voltage on the Upconverter Mainboard (fan connector X240 red to GND, do not unplug the connector). If the 12 V supply voltage is missing, there might be a problem with the power supply of the Upconverter Mainboard.

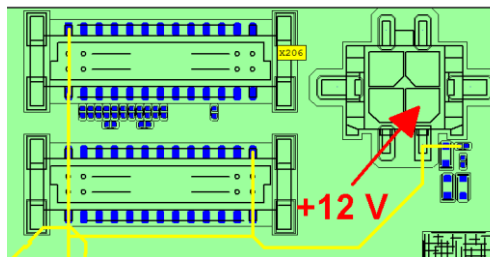

Figure 3-5: Measuring the 12 V power supply on the Upconverter Mainboard

If the power supply of the Upconverter Mainboard is ok, measure the 12 volt supply voltage of the Doubler Board at test point TP7 shown in figure XX:

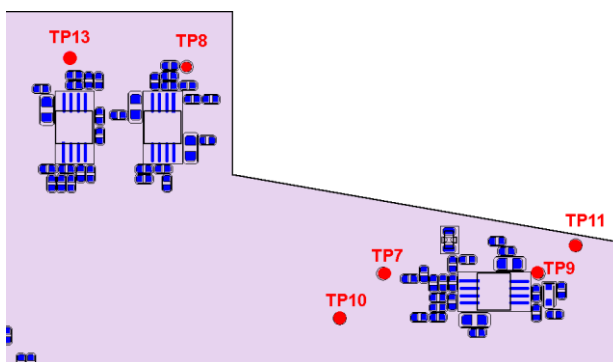

Figure 3-6: Location of the test points to measure the supply voltages

If the voltage at TP7 is not in the range of 11...13 V, please change the connector cable XX and test the 12 V supply voltage again. If TP7 still doesn't show the right voltage, change the Doubler Board.

In other case, use the following test points to ensure that the other supply voltages of the doubler board comply with the values given in the table below. If one voltage is out of the required level, change the module.

Test point	Description	Voltage range
TP9	-12.0 V	-11.5 ... -12.5 V
TP8	+5 V ref NT	+4.95 V ... +5.05 V
TP13	+5 V ref (before shunt)	+5.3 V ... +6.3 V
TP11	-12 V supplying -10 V	- 10.5 V ... - 12.5 V
TP10	+12 V supplying +10 V	+10.5 V ... +12.5 V

3.2.13.1 Input and Output Signals

Run the internal self test (see page 55) in order to check the internal RF-signals of the Doubler Board (diagnosis test points: D_DBL_IN, D_DBL_ALC, D_DBL_OUT, D_AMP_IN, D_AMP_OUT). If one of the tests at D_DBL_IN or D_AMP_IN fails, there is no input signal and probably the Upconverter Mainboard or one of the RF-cables W207, W208, W209 and W210 is defective. If both of these tests pass and at least one of the other tests fail probably the Doubler Board is defective. In this case change the module.

3.3 Module Replacement and Upgrade

This section describes in detail the replacement of modules. Chapter 5 "*Documents*" provides information on how to order spare parts. It contains the list of mechanical parts with order numbers and the illustrations for module replacement.

⚠ WARNING

Danger of injury during module replacement

Any adjustments, replacement of parts, maintenance or repair must be carried out exclusively by technical personnel authorized by Rohde & Schwarz.

Follow the step-by-step instructions for module replacement carefully to avoid injury and ensure safe operation.

NOTICE

Risk of electrostatic discharge

Protect the work area against electrostatic discharge to avoid damage to electronic components in the modules. For details, refer to the safety instructions at the beginning of this manual.

Protection of mechanical components

Always use a torque wrench (60 Ncm) to fasten all RF connectors. Do not use an open-end wrench.

Protection of electronic components

Always wear gloves when handling the electronic components.

Datasheet compliance

Recalibration of the instrument is required after any disconnection or connection of RF cables.

3.3.1 Required Tools

- Star screwdriver TX 8
- Star screwdriver TX 20
- Hex Nut-Driver 5 mm
- Torque wrench 60 Ncm (8 mm)

3.3.2 Module Overview and Information about Part Lists

Overview - Module Replacement

Module	Designation	Instrument Part No.	Replacement Part Order No.	Page Ref.
Power Supply Unit (AC 90 V to 264 V)	A50	1416.0870.00	1416.0870.00	76
Controller Board	A100	1416.1201.02	1416.1201.02 Rev ≥ 6.00	88
RF Upconverter 20 GHz, incl. in R&S SGU-B120	A200	1418.2705.03	1418.2705.03	82
RF Upconverter 20 GHz, incl. in R&S SGU-B120V	A200	1418.2705.02	1418.2705.02	82
UPCON 40 Module CW, incl. in R&S SGU-B140	A400	1315.2003.03	1315.2003.03	91
UPCON 40 Module IQ, incl. in R&S SGU-B140V	A400	1315.2003.02	1315.2003.02	91
Frontmoduleboard	A300	1419.4801.02	1419.4801.02	80
Step Attenuator 115dB 5dB, incl. in R&S SGU-B26	A500	1170.0113.02	1170.0113.02	94
Fan 12VDC	E1	3584.3900.00	3584.3900.00	90

Notes: *All modules can be replaced by modules with the same part number or by replacement modules as listed above. The words "left" and "right" in the manual always refer to the front view of the instrument.*

The part numbers used in the manual are equal to the position numbers in the part lists.

In the following part lists you can find the material numbers to order spare parts:

<i>Pos. < 1000</i>	<i>1418.2005.01 ST</i>	<i>SGU100A</i>
<i>Pos. ≥ 1000</i>	<i>1418.2605.01 ST</i>	<i>SGU-B120</i>
	<i>1418.2657.01 ST</i>	<i>SGU-B120V</i>
<i>Pos. ≥ 1300</i>	<i>1418.2870.01 ST</i>	<i>SGU-B140</i>
	<i>1418.2928.01 ST</i>	<i>SGU-B140V</i>
<i>Pos. ≥ 1600</i>	<i>1418.3401.01 ST</i>	<i>SGU-B26</i>

3.3.3 After Replacing an Assembly

After you have replaced one of the assemblies, certain adjustments, functional checks or performance tests have to be carried out. Please refer to chapter 2 "[Adjustment](#)".

3.3.4 Removing the Case

NOTICE

Risk of damage to the instrument.

Ensure that the power supply cord is disconnected.

1. Unfasten the two rear feet (480) and take them off.



2. For removing the two covers - lower (350) and top (380) - push it backwards. Then remove it.



3.3.5 Installing the Case

1. For installing the covers - lower (350) and upper (380) – put the cover holders into the slots of the unit and then push it frontwards.



2. Put the two rear feet (480) on the instrument and fasten it.



3.3.6 Replacing the EMC Panel

3.3.6.1 Removing the EMC Panel

1. Removing the case (see page 73).
2. Unfasten the six screws (290).
Unfasten the screw (1390) if there is an IQ-Upcon 40 Module assembled.
Lift up the EMC panel (280) and remove it backwards.

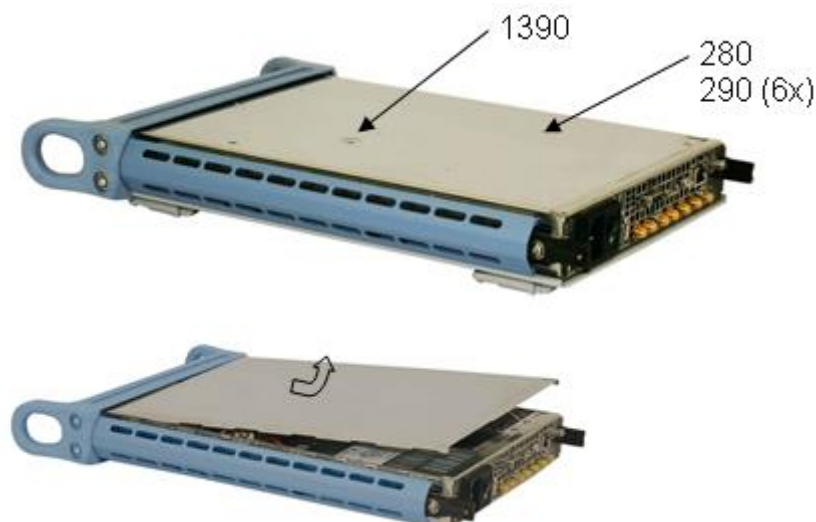

3.3.6.2 Installing the EMC Panel

1. Push the EMC panel (280) forward under the front unit and drop it down. Unfasten the six screws (290).
Unfasten the screw (1390) if there is an IQ-Upcon 40 Module assembled.
Installing the case (see page 74).



3.3.7 Replacing the Power Supply (A50)

3.3.7.1 Removing the Power Supply

1. Switch off the instrument.
2. Remove the case (see page 73).
3. Remove the EMC panel (see page 75).
4. Disconnect the right side panel (450) by pushing it backwards and removing it from the unit.

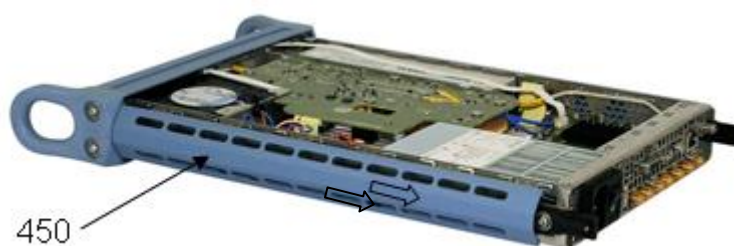

5. Unfasten the four combination screws (60).



6. Disconnect the power supply cable from X270 on the RF-Upconverter (1010/1020).
7. Lift up and remove the power supply (50).



3.3.7.2 Installing the Power Supply (A50)

1. Place the power supply (50) into the unit.
2. Connect the power supply cable on X270 of the RF-Upconverter (1010/1020).



3. Fasten the four combination screws (60).



4. Connect the side panel (450) by putting the holders of the side panel into the slots of the unit. Then push it frontwards.



5. Install the EMC panel (see page 75).
6. Install the case (see page 74).
7. Perform the necessary action described in chapter Adjustment (page 39).

3.3.8 Replacing the Front Unit

3.3.8.1 Removing the Front Unit

1. Switch off the instrument.
2. Remove the case (see page 73).
3. Remove the EMC panel (see page 75).
4. Unfasten the four screws (180) and remove the two front grips (170).

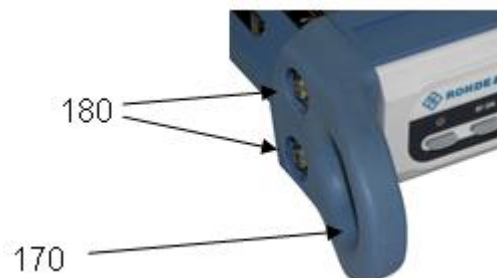

5. Disconnect the flat flexible cable (152) from X104 on the controller board (210) carefully.

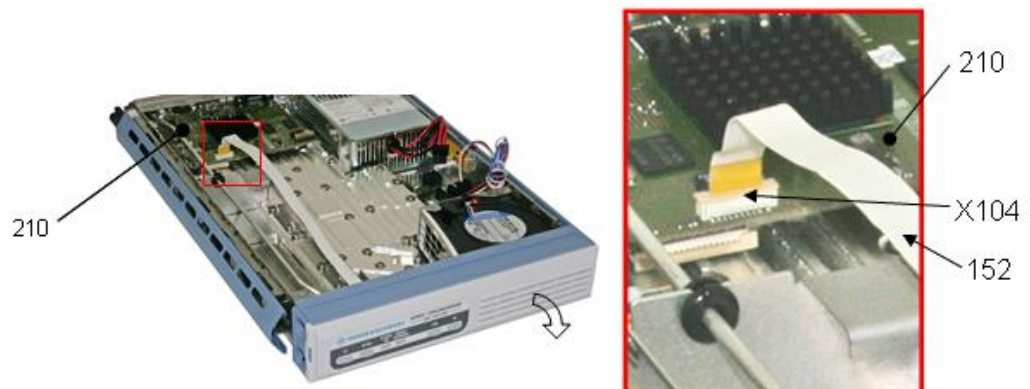

6. Pull the entire front unit forward.



3.3.8.2 Installing the Front Unit

1. Pull the flat flexible cable (152) through the slot in the front side of the housing.
2. Push the entire front unit backwards.
3. Connect the flat flexible cable (152) at X104 on the controller board (210) carefully.

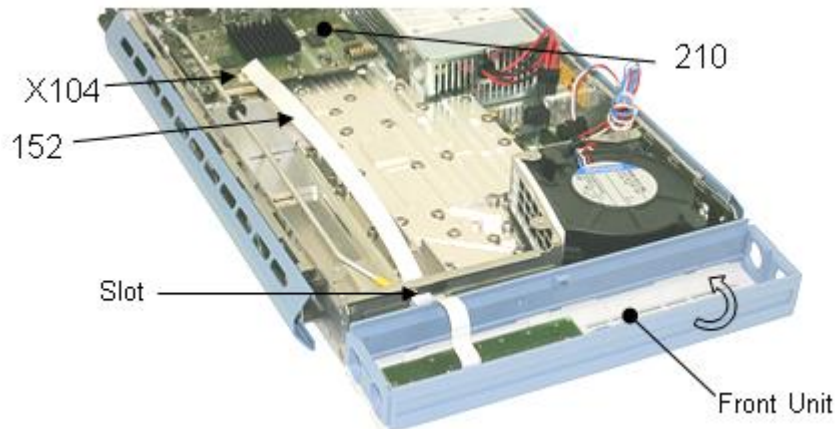

4. Put the two front grips (170) back and fasten them with the four screws (180).

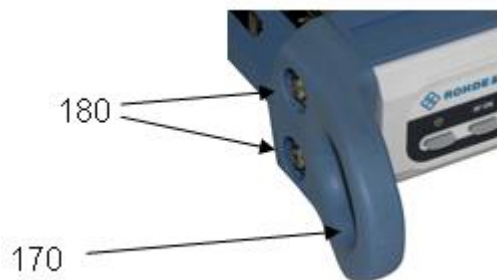

5. Install the EMC panel (see page 75).
6. Install the case (see page 73).

3.3.9 Replacing the Frontmoduleboard A300

3.3.9.1 Removing the Frontmoduleboard and the Rubber Keypad

1. Switch off the instrument.
2. Remove the case (see page 73).
3. Remove the EMC panel (see page 75).
4. Remove the front unit (see page 78).
5. Carefully push the five holders apart and remove the Frontmoduleboard A300 (150).

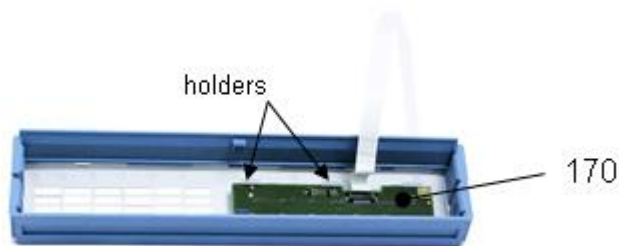

6. Remove the rubber keypad (140).



3.3.9.2 Installing the Frontmoduleboard and Rubber Keypad

1. Install the rubber keypad (140).



2. Install the Frontmoduleboard A300 (150) and click it carefully into the five holders.

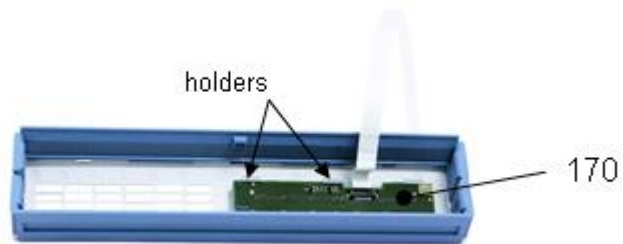

3. Install the front unit (see page 79).

3.3.10 Replacing the RF-Upconverter (A200)

3.3.10.1 Removing the RF-Upconverter

1. Remove the case (see page 73).
2. Remove the EMC panel (see page 75).
3. Remove the front unit (see page 78).
4. Unfasten the three combination screws (1x 230 and 2x 1050) on the rear of the instrument.
5. Unfasten the two locking screws (212+213) from the controller board (210) on the rear of the instrument. Use SW5.

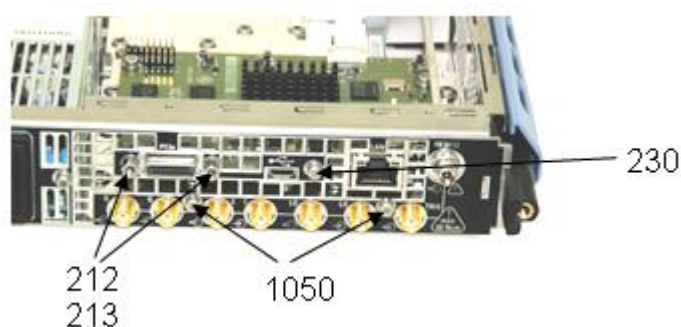

6. Unfasten the four combination screws (3x 1040 and 1x 1050) fixing the RF-Upconverter (1010/1020) to the bottom.
7. Disconnect the fan cable from X240 and the power supply cable from X270.
8. Disconnect the flat flexible cable (152) from X104 on the controller board (210) carefully.

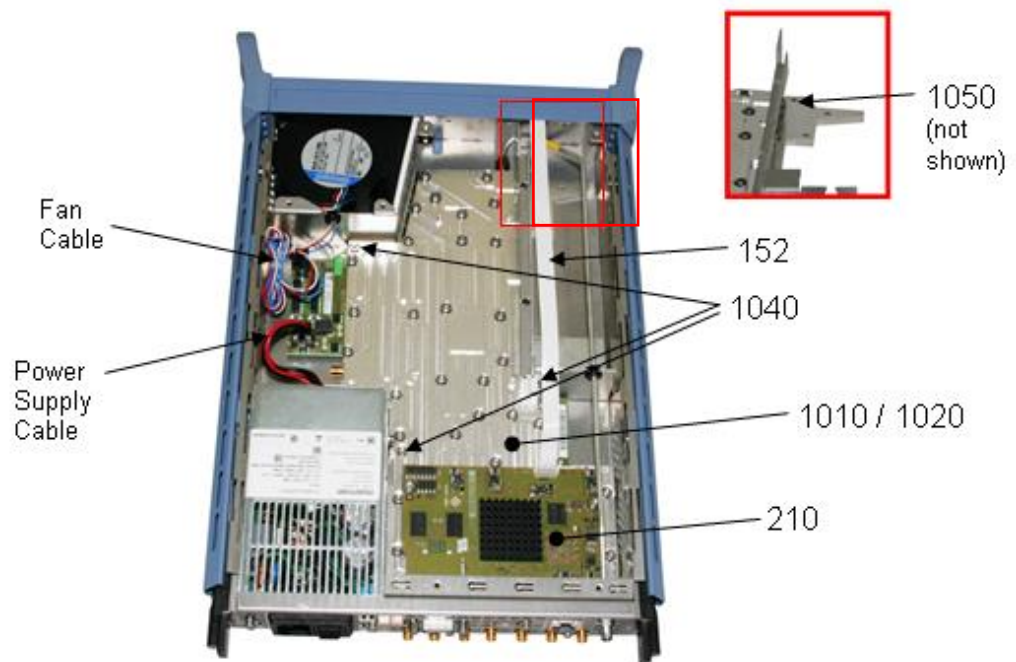

- Lift up the RF-Upconverter (1010/1020) and pull it toward the front to remove it completely with the controller board (210), with the IQ-Upcon 40 Module (1310/1320) if it is installed and with the Step Attenuator (1610) if it is installed.



10. Unfasten the three combination screws (240) and remove the controller board (210).

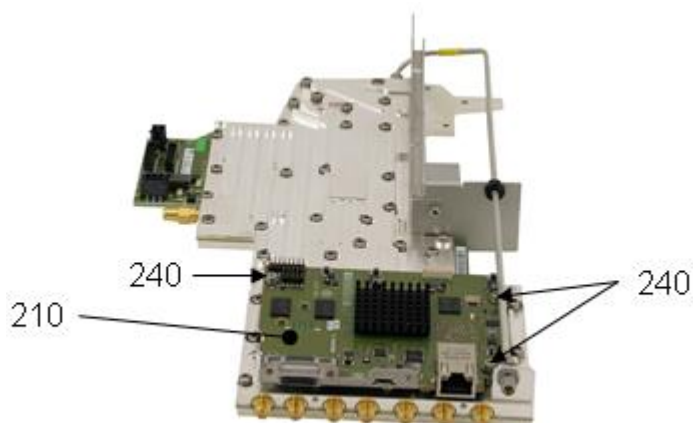

11. Unfasten the two combination screws (1080) incl. the mounting bracket (1070) and disconnect the cable
- W205B (1110) or
 - W1 (1690) if there is a step attenuator (1610) installed or
 - W2A (1380) if there is an IQ-Upcon 40 Module (1310/1320) but no step attenuator (1610) installed.

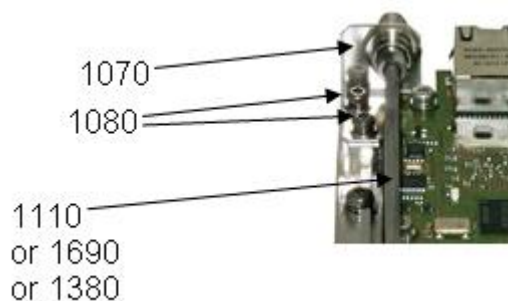

12. Remove the step attenuator (1610) if there is one (see page 94).
13. Remove the IQ-Upcon 40 Module (1310/1320) if there is one (see page 91).

3.3.10.2 Installing the RF-Upconverter (A200)

1. Install the IQ-Upcon 40 Module (1310/1320) if there is one (see page 92).
2. Install the step attenuator (1610) if there is one (see page 96).
3. Fasten the cable
 - a) W205B (1110) or
 - b) W1 (1690) if there is a step attenuator (1610) installed or
 - c) W2A (1380) if there is an IQ-Upcon 40 Module (1310/1320) but no step attenuator (1610) installed.

incl. the mounting bracket (1070) with the two combination screws (1080) on the RF-Upconverter (1010/1020).

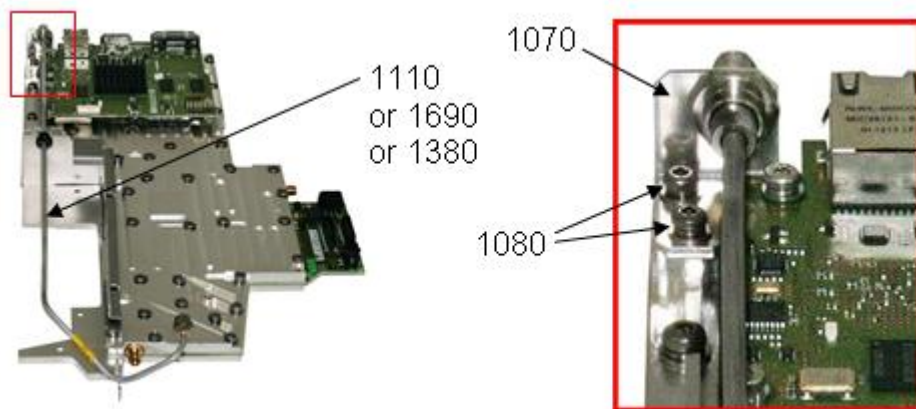

4. Place the controller board (210) on the RF-Upconverter and fasten it with the three combination screws (240).

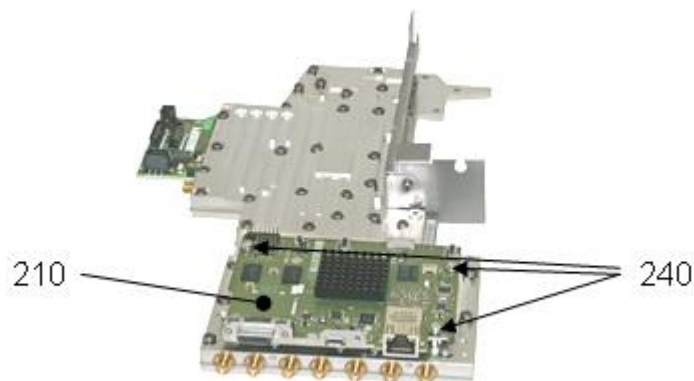

5. Place the RF-Upconverter (1010/1020), with the controller board (210) pointing forward, into the unit and insert it carefully.



6. Connect the fan cable on X240 and the power supply cable on X270.
7. Connect the flat flexible cable (152) at X104 on the controller board (210) carefully.
8. Fasten the four combination screws (3x 1040 and 1x 1050) to fix the RF-Upconverter (1010/1020) to the bottom.

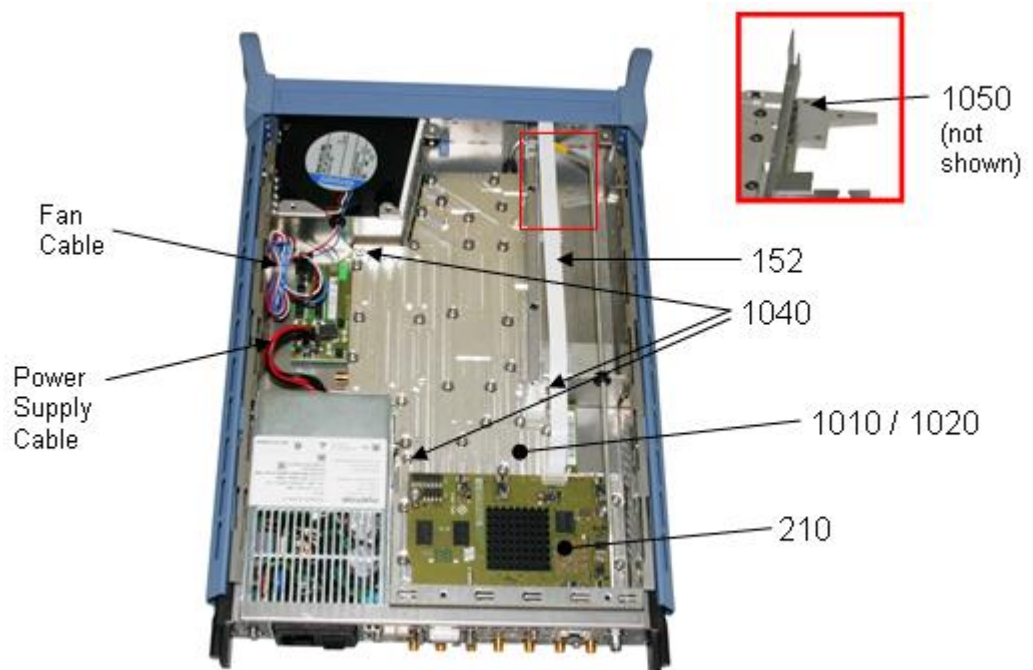

9. Fasten the three combination screws (1x 230 and 2x 1050) on the rear of the instrument.
10. Fasten the two locking screws (212+213) on the controller board (210) on the rear of the instrument. Use SW5.

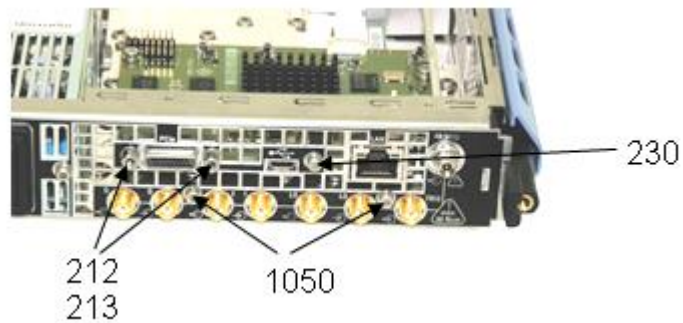

11. Install the front unit (see page 79).
12. Install the EMC panel (see page 75).
13. Install the case (see page 74).
14. Perform the necessary action described in chapter Adjustment (page 39).

3.3.11 Replacing the Controller Board A100

The controller board (210) is located on the RF-Upconverter.

3.3.11.1 Removing the Controller Board

To remove the Controller Board (210), refer to [Removing the RF-Upconverter](#) and attend orders until Step 10.

NOTICE

If you replace the controller board, you have to remove the SIM card (see 3.3.9.3).

The SIM card is part of your instrument and will not be replaced by Rohde & Schwarz if it becomes lost. Always keep the SIM card with you.

3.3.11.2 Installing the Controller board (A100)

!!! Make sure the correct SIM card is attached to the controller board !!!

To install the Controller Board (210), refer to [Removing the RF-Upconverter](#) and attend orders beginning at Step 4.

3.3.11.3 Replacing the SIM Card

1. Remove the controller board (see page 88).
The SIM card (220) is located on the bottom of the controller board (210).
2. Open the latch of the SIM card holder by sliding the retaining bracket toward OPEN.

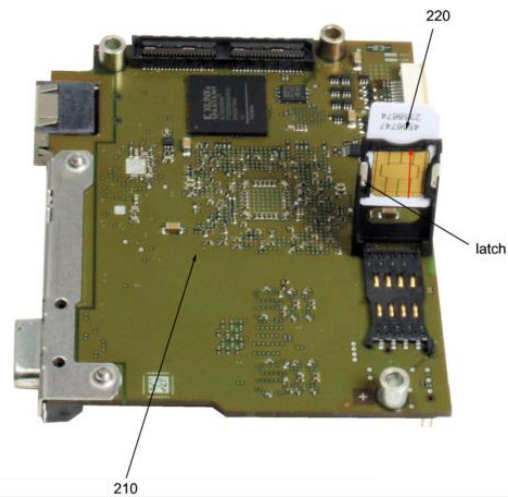

Position of SIM card holder can be different.

3. Flip up the SIM card holder and remove the SIM card (220).
4. For installing the SIM card, proceed in reverse order.

3.3.12 Replacing the Fan E1

Note: Always make sure the instrument fan operation is not constrained by dust etc.
The fan can be inspected through the air intake at the case bottom side.

1. Switch off the instrument and disconnect the main plug.
2. Remove the case (see page 73).
3. Remove the EMC panel (see page 75).
4. Remove the front unit (see page 78)
5. Disconnect the fan cable from X240 on the RF-Upconverter (1010 or 1020).
6. Take off the grommet (120) carefully.

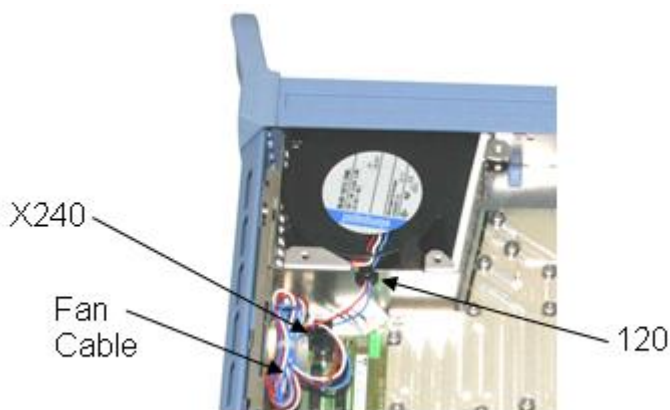

7. Lift out the fan (100) with the two rubber clips (110).

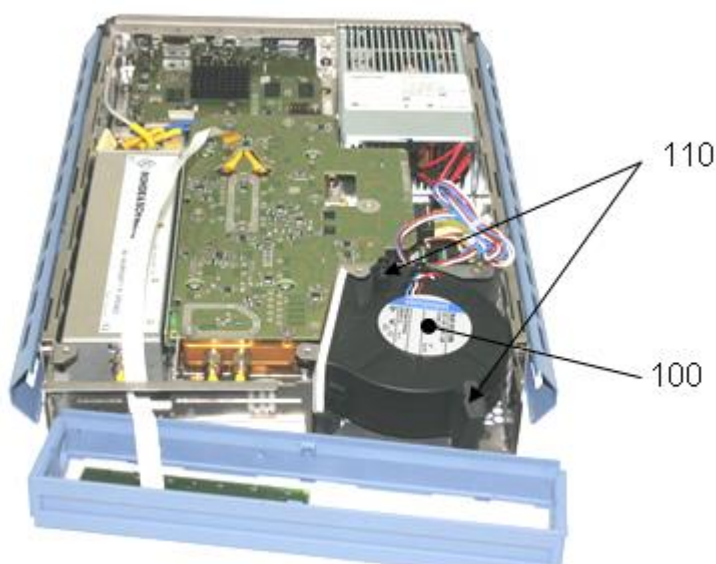

8. Take off the rubber clips (110) from the fan (100) and put it on the new fan.
9. Install the new fan by proceeding in the reverse order.

3.3.13 Replacing the IQ-Upcon 40 Module - R&S SGU-B140/-B140V (A400)

3.3.13.1 Removing the IQ-Upcon 40 Module

1. Switch off the instrument and disconnect the main plug
2. Remove the case (see page 73).
3. Remove the EMC panel (see page 75).
4. Remove the front unit (see page 78).
5. Remove the RF-Upconverter (see page 82).
6. Disconnect the ribbon cable W211 (1350) from X405 on IQ-Upcon 40 Module.
7. Disconnect the flexible RF cables W243 and W244 from the RF-Upconverter (1010/1020).
8. Disconnect the RF cables W205 (1370) and W241 (1360) from the IQ-Upcon 40 Module and from the RF-Upconverter (1010/1020).
9. Take off the grommet (264) carefully and disconnect the RF cable
 - a) W2A (1380) or
 - b) W2 (1670) if there is a step attenuator (1610).

from the IQ-Upcon 40 Module (1310/1320) and from the rear of the instrument respectively from the step attenuator (1610).
10. Unfasten the four screws (1330) and remove the IQ-Upcon 40 Module from the RF-Upconverter.
11. Remove the IQ-Upcon 40 Module (1310/1320)

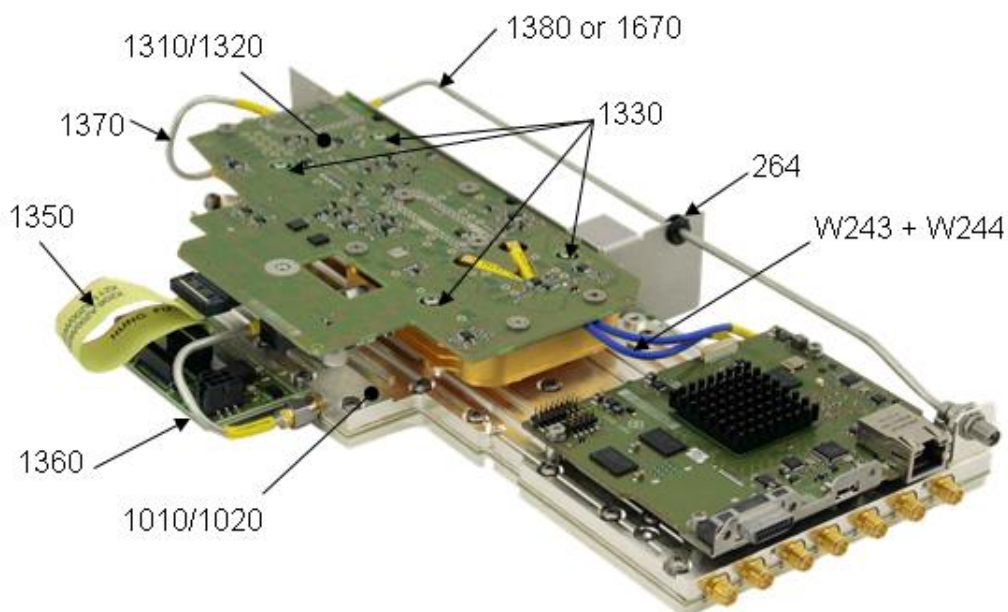

3.3.13.2 Installing the IQ-Upcon 40 Module

CAUTION

Risk of shock hazard and instrument damage

When replacing the step attenuator and/or the IQ-Upcon 40 Module, be aware of connecting the ribbon cables (W211/W213) with the right connector of the RF-Upconverter.

1. Switch off the instrument and disconnect the main plug.
2. Remove the case (see page 73).
3. Remove the EMC panel (see page 75).
4. Remove the RF-Upconverter (see page 82).
5. Place the IQ-Upcon 40 Module (1310/1320) on the RF-Upconverter (1010/1020).
6. Connect the RF cable
 - a) W2 (1670) or
 - b) W2A (1380) if there is a step attenuatorto X2 on the IQ-Upcon 40 Module (1310/1320) and to the rear of the instrument respectively to X2 on the step attenuator.
Put the grommet (264) on the sheet.
7. Connect the RF cables W241 (1360) to X1 on the IQ-Upcon 40 Module (1310/1320) and to X241 on the RF-Upconverter (1010/1020).
8. Connect the RF cables W205 (1370) to X3 on the IQ-Upcon 40 Module (1310/1320) and to X205 on the RF-Upconverter (1010/1020).
9. Connect the flexible RF cables W243 to X243 and W244 to X244 on the RF-Upconverter (1010/1020).
10. Connect the ribbon cable W211 (1650) to X405 on the IQ-Upcon 40 Module (1310/1320) and to X211 on the RF-Upconverter (1010/1020).
11. Fix the IQ-Upcon 40 Module (1310/1320) on the RF-Upconverter (1010/1020) with four screws (1330).

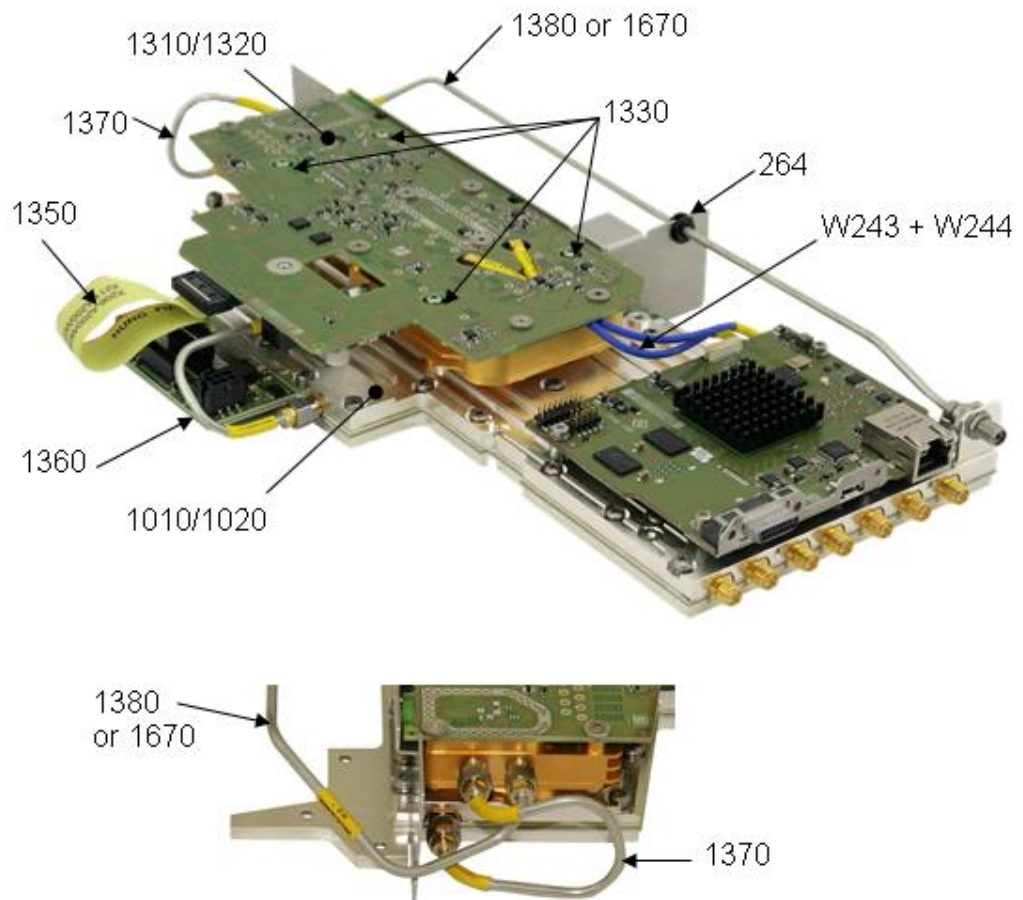

12. Install the RF-Upconverter (see page 85).
13. Install the EMC panel (see page 75).
14. Install the case (see page 74).
15. Perform the necessary action described in chapter Adjustment (page 39).

3.3.14 Replacing the Step Attenuator (A500) – R&S SGU-B26

3.3.14.1 Removing the Step Attenuator

1. Switch off the instrument and disconnect the main plug.
2. Remove the case (see page 73).
3. Remove the EMC panel (see page 75).
4. Remove the RF-Upconverter (see page 82).
5. Disconnect the RF cable W1 (1690) from X1 on the step attenuator (1610)
6. Disconnect the RF cable
 - a) W205A (1680) or
 - b) W2 (1670) if there is an IQ-Upcon 40 Module (1310/1320) installed
7. Disconnect the ribbon cable W213 (1660) from X00 on the step attenuator (1610).

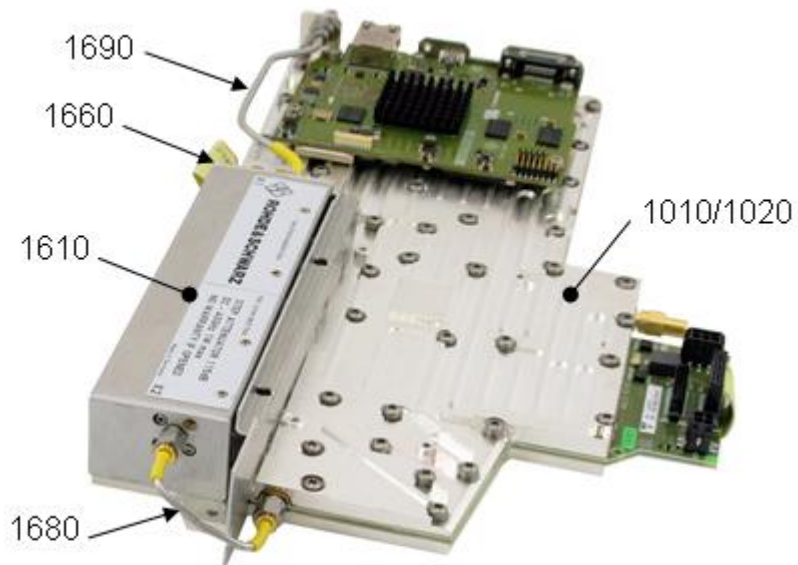

8. Unfasten the three screws (1630) and remove the step attenuator (1610).

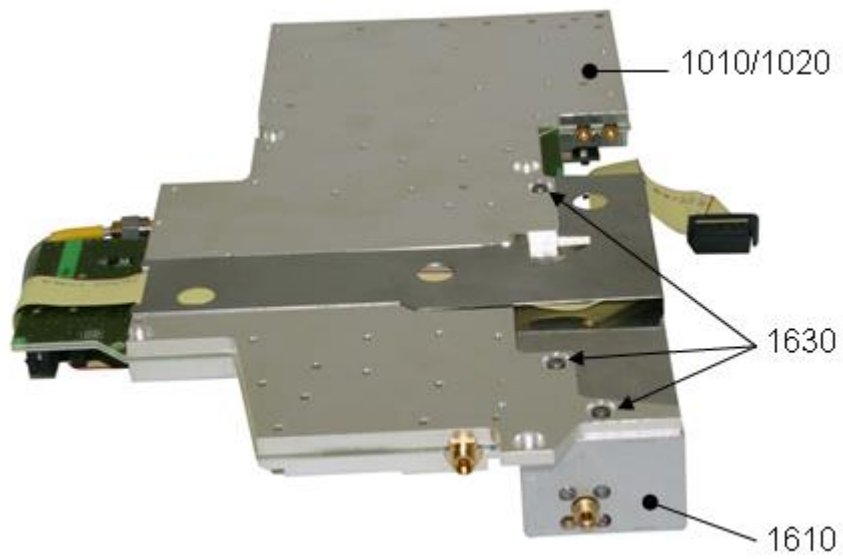

3.3.14.2 Installing the Step Attenuator

⚠ CAUTION

Risk of shock hazard and instrument damage

When replacing the step attenuator and/or the IQ-Upcon 40 Module be aware of connecting the ribbon cables (W211/W213) with the right connector of the RF-Upconverter.

1. Switch off the instrument and disconnect the main plug.
2. Remove the case (see page 73).
3. Remove the EMC panel (see page 75).
4. Remove the RF-Upconverter (see page 82).
5. Disconnect the cable
 - a) W205B (1110) or
 - b) W2A (1380) if there is a IQ-Upcon 40 Module from the RF-Upconverter (1010/1020).

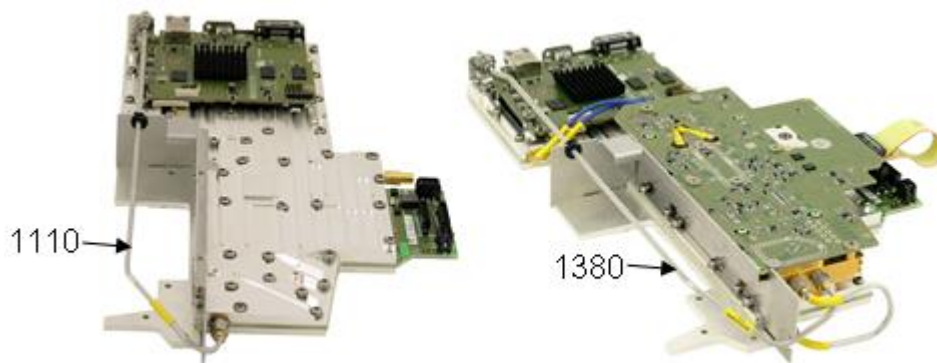

6. Place the Step Attenuator (1610) on the RF-Upconverter (1010/1020).
7. Connect the new RF cable
 - a) W205A (1680) to X205 of the RF-Upconverter (1020/1010) and to X2 on the step attenuator (1610) or
 - b) W2 (1670) to X2 of the IQ-Upcon 40 Module and to X2 on the step attenuator (1610) if there is a IQ-Upcon 40 Module (1310/1320).
8. Connect the new RF cable W1 (1690) to the rear of the instrument by putting the lock washer on and fastening the nut and to X1 of the step attenuator (1610).
9. Connect the ribbon cable W213 (1660) to X206 of the RF-Upconverter (1010/1020) and to X00 of the step attenuator (1610)

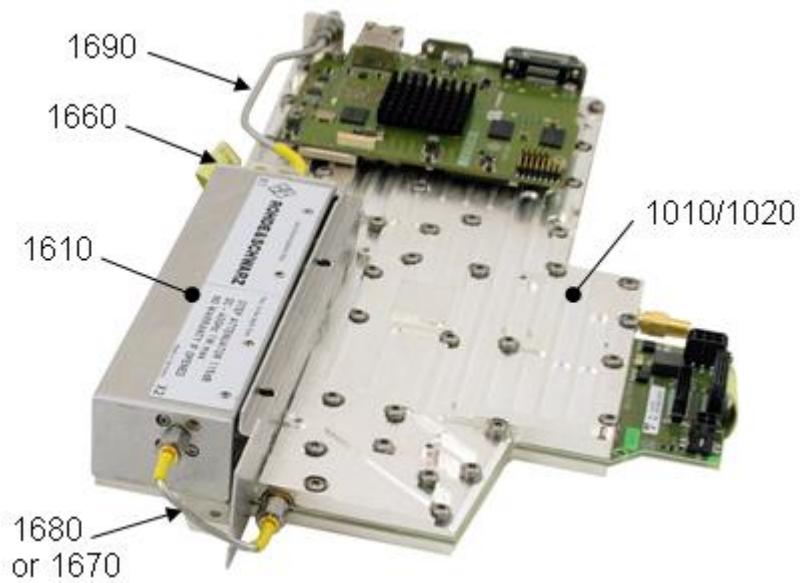

10. Connect the step attenuator (1610) with the three screws (1630).

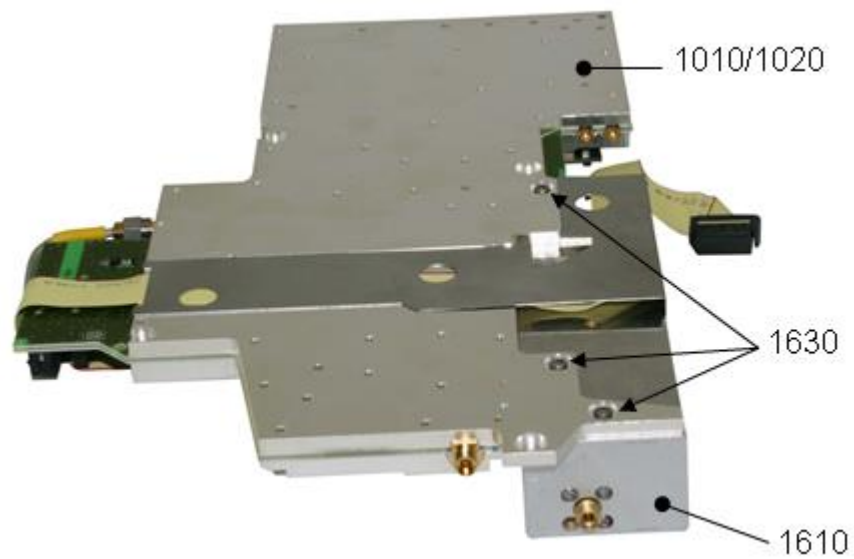

11. Install the RF-Upconverter (see 85).
12. Install the EMC panel (see page 75).
13. Install the case (see page 74).
14. Perform the necessary action described in chapter Adjustment (page 39).

4 Firmware Update

1. Connect the SGU100A directly to the SGMA-GUI Software. The Firmware update cannot be started by the LO source instrument.
2. Select "SGMA-GUI main panel > Instrument Name > Setup > Maintenance > Operation > Install firmware package".
3. Press "Select Package" and navigate to the directory the new firmware is stored in.
4. Enter the "Security Password".
5. Confirm the update with "Accept".
The software transfers the firmware file and automatically starts the update procedure. During the update, the message "Updating Firmware" is displayed in the Info line.
Note: *The update procedure requires restart of the instrument. The restart is performed automatically. The instrument is not accessible during that time.*
6. Wait until the message "Updating Firmware" disappears and the update is completed. The green POWER ON/STANDBY LED is on.
7. After installation of a new Firmware, internal adjustment of the instrument is required. Connect the SGU100A to the LO source and start the internal adjustment. Performing the adjustment with checkbox "extension only" activated is sufficient.
Tip: *Calibration Error. If the Info line shows the message "Calibration Error", select "SGMA-GUI main panel > Instrument Name > Setup > Internal Adjustments > Adjust All" to trigger internal adjustment.*
8. If required, install the new R&S SGMA-GUI.
For detailed description, refer to the Getting Started guide, section "Installing the R&S SGMA-GUI Software on the External PC".

5 USB Install

Hold down front panel buttons ID and LAN simultaneously while switching on the instrument to start factory recover or USB install.

If a USB stick with a firmware package (*.rsu file) is found the firmware package on the USB stick is installed on the instrument.

The progress of the installation procedure is signaled by a running light on the front panel. When it is finished the lights stop and the LEDs now indicate the status. All LEDs green: success. All LEDs red except one LED orange: failure.

The position of the one orange LED indicates the reason for the failure.

- 1st (leftmost) LED: Cannot access recovery partition or USB stick
- 2nd LED: No update package or recovery package found.
- 3rd LED: Update package or recovery package defective.
- 4th LED: System partition defective.
- 5th LED: Out of flash memory
- 6th LED: Update package defective
- 7th LED: Flash memory write error

The LEDs stay on for 1 minute after which the instrument performs an automatic reboot.

6 Documents

6.1 Spare Parts

The stock numbers necessary for ordering replacement parts and modules can be found in the spare part list further down.

CAUTION

Risk of shock hazard and instrument damage

When replacing a module please note the safety instructions and the repair instructions given in chapter 3 and at the beginning of this service manual.

When shipping a module be careful to provide for sufficient mechanical and antistatic protection.

6.1.1 Available Power Cables

Stock No	Earthed-contact connector	Preferably used in
DS 0006.7013.00	S1363: 1967' 10 A, 250 V complying with IEC 83: 1975 standard B2	Great Britain
DS 0006.7020.00	Type 12, 10 A, 250 V complying with SEV-regulation 1011.1059, standard sheet S 24 507	Switzerland
DS 0006.7036.00	Type 498/13, 10 A, 250 V complying with US-regulation UL 498, or with IEC 83	USA/Canada
DS 0041.4752.00	GB2099, GB1002, 10 A, 250 V approvals CCC	China
DS 0041.6232.00	JIS C 8303, 7A, 125 V AC approvals PSE (JET)	Japan
DS 0006.7107.00	Type SAA3, 10 A, 250 V, complying with AS C112-1964 Ap.	Australia
DS 0025.2365.00 DS 0099.1456.00	DIN 49 441, 10 A, 250 V, angular DIN 49 441, 10 A, 250 V, straight approvals VDE, ÖVE, CEBEC, KEMA, S, D, N, FI, LCIE, IMQ, UCIEEEurope	Europe (except Switzerland)

6.2 Spare Part List and Mechanical Drawings

Für diese Unterlage behalten wir uns alle Rechte vor.
 Ausgedruckte Dokumente unterliegen nicht dem Änderungsdienst.
 For this document all rights are reserved.
 Printed documents are not subject to revision

Pos.-Nr. ItemNo	Menge Quantity	ME Unit	El.Kennz Ref.Des.	Benennung / Bezeichnung Designation	Z	Sachnummer Stock No.	Ersatzteil Subst.part	BA	VH
				ACHTUNG EGB/ATTENTION ESD *VARIANTENERKLAERUNG +EXPLANATION OF VARIANTS *VAR02=GRUNDVARIANTE +VAR02=BASIC MODEL					
5	0	S		ZS ERSATZTEILLISTE VORHANDEN SPARE PARTS LIST AVAIL Sach-Nr. / Part No. 1418.2040.01 ST für / for SGU100A		0999.9684.00		M	O
20	1	S		KB GERAETEWANNE BESCHR. FUER SGU HOUSING TROUGH PRINTED	Z	1418.2192.00		M	P
50	1	S	A50	NJ PSU-0251-02 PSU 1X 75W 12.2V 6.15A AC/DC POWER SUPPLY UNIT		1416.0870.00	X	B	T
60	4	S		VS 6900/ISR M2.5X6 A2 COMBI SCREW 6900/ISR M2.5 X 6 A2		1148.3059.00		B	T
100	1	S	E1	EV LUEFTER 76X27 6.1L/S 12VDC FAN 12VDC		3584.3900.00	X	B	O
102	2	S		DZ KABELBI.RD 1 BIS 25 B2 CABLETIE		0015.9038.00		B	O
104	1	S		DZ HALTER KAB.BIND 4.2 HOLDER		0794.5214.00		B	O
110	2	S		EV RADIALLUEFTER-HALTERG. 27/6MM FRILL FOR FAN		1416.0970.00	X	B	O
120	1	S		DZ DURCHF.RD4XRD9.5X5.6 GROMMET		0062.1130.00		B	B
130	1	S		MM FRONTPLATTE SIGMA FRONT COVER SIGMA		1416.0828.00	X	B	B
140	1	S		SF SCHALTMATTE SIGMA RUBBER KEYPAD SIGMA		1416.0628.00	X	B	B
150	1	S	A300	ED FRONTMODULBOARD FRONTMODULBOARD	Z	1419.4801.02	X	M	P
152	1	S	W300	DF FLEXSTRIP 16POL R= 0.5 L=270 FFC FLAT FLEXIBLE CABLE 16P 0.5MM		5705.6286.00		B	O
154	.015	M		WW KLEB-BD0.3 X15GEWEB GR ADHESIVE TAPE		0016.8412.00		B	O
160	2	S		KN BW2010 RAHMENTEIL 1/2 BW2010 FRAME 1/2		1174.0047.00		B	T
170	2	S		KN BW2010 1E GESTELLGRIFF BW2010 1U RACK MOUNT GRIP		1174.2940.00		B	T
180	4	S		VS SCHR. M4X18 ISR PA SCREW M4 X 18 ISR PA		1096.4944.00		B	B
210	1	S	A100	ED CONTROLLER BOARD CONTROLLER BOARD	Z	1416.1201.02	X	M	A
212	2	S		FM VERRIEGEL.BOLZEN H=5.3 LOCKING SCREW 4-40UNC H=5.3		6105.0437.00		B	O
213	2	S		VS DIN128 A3 A2 SPRING LOCK WASHER DIN128 A3 A2		0005.2499.00		B	O
220	1	S		BC SMARTCARD SLE66 V4.4 SIM FORMAT SMARTCARD SLE66 V4.4 SIM FORMAT		3586.7860.00		B	O
230	1	S		VS 6900/ISR M2.5X6 A2 COMBI SCREW 6900/ISR M2.5 X 6 A2		1148.3059.00		B	T



ROHDE & SCHWARZ

Benennung/Designation

SGU100A SGMA UPCONVERTER
SGU100A SGMA UPCONVERTER

Sprach./Lang
de en

Ä.I. / C.I.
09.00

Blatt/Sheet
1 of 2

Dokument Nr. / Document No.

1418.2005.01 ST

SGU100A

Datum/
Date 2014-10-07

Abt. /
Dept. 1GPK

Name /
Name HI

Für diese Unterlage behalten wir uns alle Rechte vor.
 Ausgedruckte Dokumente unterliegen nicht dem Änderungsdienst.
 For this document all rights are reserved.
 Printed documents are not subject to revision

Pos.-Nr. ItemNo	Menge Quantity	ME Unit	El.Kennz Ref.Des.	Benennung / Bezeichnung Designation	Z	Sachnummer Stock No.	Ersatzteil Subst.part	BA	VH
240	3	S		VS HVC/ISR M2.5X12 A2 COMBI SCREW HVC/ISR M2.5 X 12 A2		1096.5205.00		B	B
250	1	S		MZ LUFTFUEHRUNG AIRFLOW PANEL		1418.3324.00		M	P
252	2	S		VS 6900/ISR M2.5X5 A2 COMBI SCREW 6900/ISR M2.5 X 5 A2		0041.1630.00		B	T
260	1	S		MZ QUERBLECH AN STELLE EICHLEITG. PANEL entfällt in Kombination mit SGU-B26 not applicable in combination with SGU-B26		1418.3318.00		M	P
262	1	S		VS 6900/ISR M2.5X5 A2 COMBI SCREW 6900/ISR M2.5 X 5 A2 entfällt in Kombination mit SGU-B26 not applicable in combination with SGU-B26		0041.1630.00		B	T
264	1	S		DZ DURCHF.RD4XRD9.5X5.6 GROMMET entfällt in Kombination mit SGU-B26 not applicable in combination with SGU-B26		0062.1130.00		B	B
275	1	S	A201	FJ ABSCHLUSSW.50OHM SMA 0.5W TERMINATION 50 OHM entfällt in Kombination mit SGU-B140 oder SGU-B140V not applicable in combination with SGU-B140 or SGU-B140V		0249.7823.00		B	B
276	1	S	A202	FJ ABSCHLUSSW.50OHM SMA 0.5W TERMINATION 50 OHM		0249.7823.00		B	B
280	1	S		ZM EMV-HAUBE M. ISOL.FOL. + PAD EMV-COVER WITH ISOL.FOIL + PAD	Z	1418.2328.00		M	P
290	6	S		VS 965/ISR M2.5X5 A4 PA 965/ISR M2.5 X 5 A4 PA		1148.2752.00		B	T
300	1	S		HS FIRMWARE SGU100A FIRMWARE SGU100A	Z	1418.2034.00		M	V
320	1	S		OS CSA-SCHILD MIT KCC FUER KOREA (SGU) CSA LABEL INCL. KCC FOR KOREA		1418.2370.00		M	P
350	1	S		ZN BW2010 1E 1/2 T350 ABD. UNTEN PERF BW2010 1E 1/2 T350 COVER LOWER	Z	1416.0911.00		M	P
360	4	S		KN BW2010 GERAETEFUSS 12MM KOMPL. BW2010 FOOT 12MM COMPL.		1174.2227.00		B	T
380	1	S		MZ BW2010 1E 1/2 T350 ABDECKUNG OBEN BW2010 1E 1/2 T350 COVER TOP		1174.0082.00		M	O
450	2	S		MZ BW2010 1E T350 SEITENTEIL LINKS BW2010 1U D350 SIDE PANEL LEFT		1174.1172.00		M	O
480	2	S		KN BW2010 1E RUECKWANDFUSS KOMPL BW2010 1HU REAR FOOT COMPL	Z	1174.0024.00		B	T
720	2	S		KN BW2010 HALTER-FUSS BW2010 HOLDER BASE		1174.0353.00		B	T
730	2	S		VS SCHR. M4X10 ISR PA SCREW M4 X 10 ISR PA		3586.3313.00		B	B



ROHDE & SCHWARZ

Benennung/Designation

SGU100A SGMA UPCONVERTER
SGU100A SGMA UPCONVERTER

Sprach./Lang
de en

Ä.I. / C.I
09.00

Blatt/Sheet
2 of 2

Dokument Nr. / Document No.

1418.2005.01 ST

SGU100A

Datum/
Date 2014-10-07

Abt. /
Dept. 1GPK

Name /
Name HI

Für diese Unterlage behalten wir uns alle Rechte vor.
 Ausgedruckte Dokumente unterliegen nicht dem Änderungsdienst.
 For this document all rights are reserved.
 Printed documents are not subject to revision

Pos.-Nr. ItemNo	Menge Quantity	ME Unit	El.Kennz Ref.Des.	Benennung / Bezeichnung Designation	Z	Sachnummer Stock No.	Ersatzteil Subst.part	BA	VH
5 0		S		ACHTUNG EGB/ATTENTION ESD *VARIANTENERKLAERUNG *EXPLANATION OF MODELS VAR02=GRUNDVARIANTE MOD02=BASIC MODEL PH BEMERKUNG NOTE Die Montage dieser Option ins Gerät SGU100A ist in der Zeichnung D1418.2005.01 D1 ... D3 dargestellt. ----- The installation of this option in the instrument SGU100A is shown in the drawing D1418.2005.01 D1 ... D3		0999.9610.00		B	O
1610	1	S	A500	ZE EICHLITUNG 115DB 5DB STEP ATTENUATOR 115DB 5DB	Z	1170.0113.02		M	P
1630	3	S		VS 6900/ISR-M2.5X6-A2 COMBI SCREW 6900/ISR-M2.5X6-A2		1148.3059.00		B	T
1660	1	S	W213	DY FLACHBANDKABEL W213 EICHL ZU UPCONV RIBBON CABLE W213 ATT TO UPCONV	Z	1418.2563.00		M	O
1662	1	S		MZ FLACHBANDKABELSCHUTZ UND - HALTER CABLESHIELDING AND -HOLDER		1418.3453.00		M	P
1670	1	S	W2	DW HF-KABEL W2 (EICHLTG ZU 40GHZ- MW) RF CABLE W2 (ATT TO 40GHZ-MW) nur in Kombination mit SGU-B140 oder SGU- B140V only in combination with SGU-B140 or SGU- B140V	Z	1418.2428.00		M	O
1680	1	S	W205A	DW HF-KABEL W205A (EICHLTG ZU UPCONV) RF CABLE W205A (ATT TO UP CONV) entfällt in Kombination mit SGU-B140 oder SGU-140V not applicable in combination with SGU-B140 or SGU-B140V	Z	1418.2434.00		M	O
1690	1	S	W1	DW HF-KABEL W1 (RUECKWAND ZU EICHLTG) RF CABLE W1 (REAR PANEL TO ATT)	Z	1418.2411.00		M	O



ROHDE & SCHWARZ

Benennung/Designation

SGU-B26 MECH. STEP ATTENUATOR
SGU-B26 MECH. STEP ATTENUATOR

Sprach./Lang
de en

Ä.I. / C.I
03.00

Blatt/Sheet
1 of 1

Dokument Nr. / Document No.

1418.3401.01 ST

SGU-B26

Datum/
Date 2013-03-12

Abt. /
Dept. 1GPK

Name /
Name HI

Für diese Unterlage behalten wir uns alle Rechte vor.
 Ausgedruckte Dokumente unterliegen nicht dem Änderungsdienst.
 For this document all rights are reserved.
 Printed documents are not subject to revision

Pos.-Nr. ItemNo	Menge Quantity	ME Unit	El.Kennz Ref.Des.	Benennung / Bezeichnung Designation	Z	Sachnummer Stock No.	Ersatzteil Subst.part	BA	VH
5 0		S		ACHTUNG EGB/ATTENTION ESD *VARIANTENERKLAERUNG *EXPLANATION OF MODELS VAR02=GRUNDVARIANTE MOD02=BASIC MODEL PH BEMERKUNG NOTE Die Montage dieser Option in den SGU100A ist in der Zeichnung D1418.2005.01 D1 ... D3 dargestellt. ----- The installation of this option in the SGU100A is shown in the drawing D1418.2005.01 D1 ... D3		0999.9610.00		B	O
1010 1		S	A200	ED RF UPCONVERTER 20 GHZ RF UPCONVERTER 20 GHZ	Z	1418.2705.03		M	W
1022 1		S		OS GERAETESCHILD SGMA SGU 20 GHZ CW LABEL SGMA SGU 20 GHZ CW entfällt in Kombination mit SGU-B140 / not applicable in combination with SGU-B140		1418.2628.00		B	B
1040 3		S		VS HVC/ISR-M2.5X12-A2 COMBI SCREW HVC/ISR-M2.5X12-A2		1096.5205.00		B	B
1050 3		S		VS 6900/ISR-M2.5X6-A2 COMBI SCREW 6900/ISR-M2.5X6-A2		1148.3059.00		B	T
1070 1		S		MZ HALTEWINKEL F. HF-AUSGANG MOUNTING BRACKET	Z	1418.2840.00		M	V
1080 2		S		VS 6900/ISR-M2.5X6-A2 COMBI SCREW 6900/ISR-M2.5X6-A2		1148.3059.00		B	T
1110 1		S	W205B	DW HF-KABEL W205B RUECKW. ZU UPCON RF CABLE W205B BACKPLANE TO UPCON entfällt in Kombination mit SGU-B26 und/oder SGU-B140 oder SGU-B140V not applicable in combination with SGU-B26 and/or SGU-B140 or SGU-B140V	Z	1418.2505.00		M	V



ROHDE & SCHWARZ

Benennung/Designation

SGU-B120 10MHZ TO 20GHZ, CW
SGU-B120 10MHZ TO 20GHZ, CW

Sprach./Lang
de en

Ä.I. / C. /
03.00

Blatt/Sheet
1 of 1

SGU-B120

Datum/
Date 2013-03-12

Abt. /
Dept. 1GPK

Name /
Name HI

Dokument Nr. / Document No.

1418.2605.01 ST

Für diese Unterlage behalten wir uns alle Rechte vor.
 Ausgedruckte Dokumente unterliegen nicht dem Änderungsdienst.
 For this document all rights are reserved.
 Printed documents are not subject to revision

Pos.-Nr. ItemNo	Menge Quantity	ME Unit	El.Kennz Ref.Des.	Benennung / Bezeichnung Designation	Z	Sachnummer Stock No.	Ersatzteil Subst.part	BA	VH		
				ACHTUNG EGB/ATTENTION ESD *VARIANTENERKLAERUNG *EXPLANATION OF MODELS VAR02=GRUNDVARIANTE MOD02=BASIC MODEL PH BEMERKUNG NOTE Die Montage dieser Option in den SGU100A ist in der Zeichnung D1418.2005.01 D1 ... D3 dargestellt. ----- The installation of this option in the SGU100A is shown in the drawing D1418.2005.01 D1 ... D3							
5 0		S				0999.9610.00		B	O		
1020 1		S	A200	ED RF UPCONVERTER 20 GHZ RF UPCONVERTER 20 GHZ	Z	1418.2705.02		M	P		
1024 1		S		OS GERAETESCHILD SGMA SGU 20 GHZ IQ LABEL SGMA SGU 20 GHZ IQ entfällt in Kombination mit SGU-B140V / not applicable in combination with SGU- B140V		1418.2670.00		B	B		
1040 3		S		VS HVC/ISR-M2.5X12-A2 COMBI SCREW HVC/ISR-M2.5X12-A2		1096.5205.00		B	B		
1050 3		S		VS 6900/ISR-M2.5X6-A2 COMBI SCREW 6900/ISR-M2.5X6-A2		1148.3059.00		B	T		
1070 1		S		MZ HALTEWINKEL F. HF-AUSGANG MOUNTING BRACKET	Z	1418.2840.00		M	V		
1080 2		S		VS 6900/ISR-M2.5X6-A2 COMBI SCREW 6900/ISR-M2.5X6-A2		1148.3059.00		B	T		
1110 1		S	W205B	DW HF-KABEL W205B RUECKW. ZU UPCON RF CABLE W205B BACKPLANE TO UPCON entfällt in Kombination mit SGU-B26 und/oder SGU-B140 oder SGU-B140V not applicable in combination with SGU-B26 and/or SGU-B140 or SGU-B140V	Z	1418.2505.00		M	V		
 ROHDE & SCHWARZ				Benennung/Designation		Sprach./Lang		Ä.I. / C./		Blatt/Sheet	
				SGU-B120V 10MHZ TO 20GHZ, IQ		de en		03.00		1 of 1	
SGU-B120V				Datum/ Date	2013-03-12	Abt. / Dept.	1GPK	Name / Name	HI	Dokument Nr. / Document No. 1418.2657.01 ST	

Für diese Unterlage behalten wir uns alle Rechte vor.
 Ausgedruckte Dokumente unterliegen nicht dem Änderungsdienst.
 For this document all rights are reserved.
 Printed documents are not subject to revision

Pos.-Nr. ItemNo	Menge Quantity	ME Unit	El.Kennz Ref.Des.	Benennung / Bezeichnung Designation	Z	Sachnummer Stock No.	Ersatzteil Subst.part	BA	VH		
				ACHTUNG EGB/ATTENTION ESD *VARIANTENERKLAERUNG +EXPLANATION OF VARIANTS *VAR02=GRUNDVARIANTE +VAR02=BASIC MODEL							
	2 0	S		ZS ERSATZTEILLISTE VORHANDEN SPARE PARTS LIST AVAIL Sach-Nr. / Part No. 1418.2886.01 ST		0999.9684.00		M	O		
	5 0	S		PH BEMERKUNG NOTE Die Montage dieser Option in den SGU100A ist in den Zeichnungen 1418.2005.01 D1 bis D3 dargestellt. ----- The installation of this option in the SGU100A is shown in the drawings 1418.2005.01 D1 to D3		0999.9610.00		B	O		
1310	1	S	A400	ZE IQ-UPCON 40 MODULE CW IQ-UPCON 40 MODULE CW	Z	1315.2003.03	X	M	O		
1330	4	S		VS 6900/ISR M2.5 X 25 A2 COMBI SCREW 6900/ISR M2.5 X 25 A2		3584.5502.00		B	O		
1335	1	S		VS 965/ISR M2.5 X 5 A4 PA 965/ISR M2.5 X 5 A4 PA		1148.2752.00		B	T		
1340	1	S		OS GERAETESCHILD SGMA SGU 40 GHZ CW LABEL SGMA SGU 40 GHZ CW		1418.2892.00		B	B		
1350	1	S	W211	DY FLACHBANDKABEL 26-POLIG R=1,27 RIBBON CABLE 26-POLE	Z	1416.1524.00		M	O		
1360	1	S	W241	DW HF-KABEL W241 (40GHZ ZU UP CONV) RF CABLE W241 (40GHZ TO UP CONV)	Z	1418.2457.00		M	P		
1370	1	S	W205	DW HF-KABEL W205 (40GHZ ZU UP CONV) RF CABLE W205 (40GHZ TO UP CONV)	Z	1418.2440.00		M	O		
1380	1	S	W2A	DW HF-KABEL W2A RUECKW. ZU MW MOD. RF CABLE W2A BACKPL. TO MW MOD. entfällt in Kombination mit SGU-B26 not applicable in combination with SGU-B26	Z	1418.2511.00		M	P		
				Benennung/Designation		Sprach./Lang		Ä.I. / C./		Blatt/Sheet	
				SGU-B140		2016-01-18		de en		04.00	
				Datum/Date		Abt./Dept.		Name/Name		Dokument Nr. / Document No.	
				2016-01-18		1GAK		HI		1418.2870.01 ST	

Für diese Unterlage behalten wir uns alle Rechte vor.
 Ausgedruckte Dokumente unterliegen nicht dem Änderungsdienst.
 For this document all rights are reserved.
 Printed documents are not subject to revision

Pos.-Nr. ItemNo	Menge Quantity	ME Unit	El.Kennz Ref.Des.	Benennung / Bezeichnung Designation	Z	Sachnummer Stock No.	Ersatzteil Subst.part	BA	VH		
				ACHTUNG EGB/ATTENTION ESD *VARIANTENERKLAERUNG +EXPLANATION OF VARIANTS *VAR02=GRUNDVARIANTE +VAR02=BASIC MODEL							
	2 0	S		ZS ERSATZTEILLISTE VORHANDEN SPARE PARTS LIST AVAIL Sach-Nr. / Part No. 1418.2934.01 ST		0999.9684.00		M	O		
	5 0	S		PH BEMERKUNG NOTE Die Montage dieser Option in den SGU100A ist in den Zeichnungen 1418.2005.01 D1 bis D3 dargestellt. ----- The installation of this option in the SGU100A is shown in the drawings 1418.2005.01 D1 to D3		0999.9610.00		B	O		
1320	1	S	A400	ZE IQ-UPCON 40 MODULE IQ IQ-UPCON 40 MODULE IQ	Z	1315.2003.02	X	M	O		
1330	4	S		VS 6900/ISR M2.5 X 25 A2 COMBI SCREW 6900/ISR M2.5 X 25 A2		3584.5502.00		B	O		
1335	1	S		VS 965/ISR M2.5 X 5 A4 PA 965/ISR M2.5 X 5 A4 PA		1148.2752.00		B	T		
1342	1	S		OS GERAETESCHILD SGMA SGU 40 GHZ IQ LABEL SGMA SGU 40 GHZ IQ		1418.2940.00		B	B		
1350	1	S	W211	DY FLACHBANDKABEL 26-POLIG R=1,27 RIBBON CABLE 26-POLE	Z	1416.1524.00		M	O		
1360	1	S	W241	DW HF-KABEL W241 (40GHZ ZU UP CONV) RF CABLE W241 (40GHZ TO UP CONV)	Z	1418.2457.00		M	P		
1370	1	S	W205	DW HF-KABEL W205 (40GHZ ZU UP CONV) RF CABLE W205 (40GHZ TO UP CONV)	Z	1418.2440.00		M	O		
1380	1	S	W2A	DW HF-KABEL W2A RUECKW. ZU MW MOD. RF CABLE W2A BACKPL. TO MW MOD. entfällt in Kombination mit SGU-B26 not applicable in combination with SGU-B26	Z	1418.2511.00		M	P		
 ROHDE & SCHWARZ				Benennung/Designation		Sprach./Lang		Ä.I. / C./		Blatt/Sheet	
				SGU-B140V FREQ EXT TO 40GHZ, IQ		de en		05.00		1 of 1	
SGU-B140V				Datum/Date	2016-01-18	Abt./Dept.	1GAK	Name/Name	HI	Dokument Nr. / Document No. 1418.2928.01 ST	



Alle Anschlüsse der HF-Kabel mit max. 60Ncm angezogen
 ALL CONNECTIONS OF THE RF-CABLES ATTRACTED WITH
 MAX. TORQUE 60Ncm

Achtung EGB!
 CAUTION ESD!

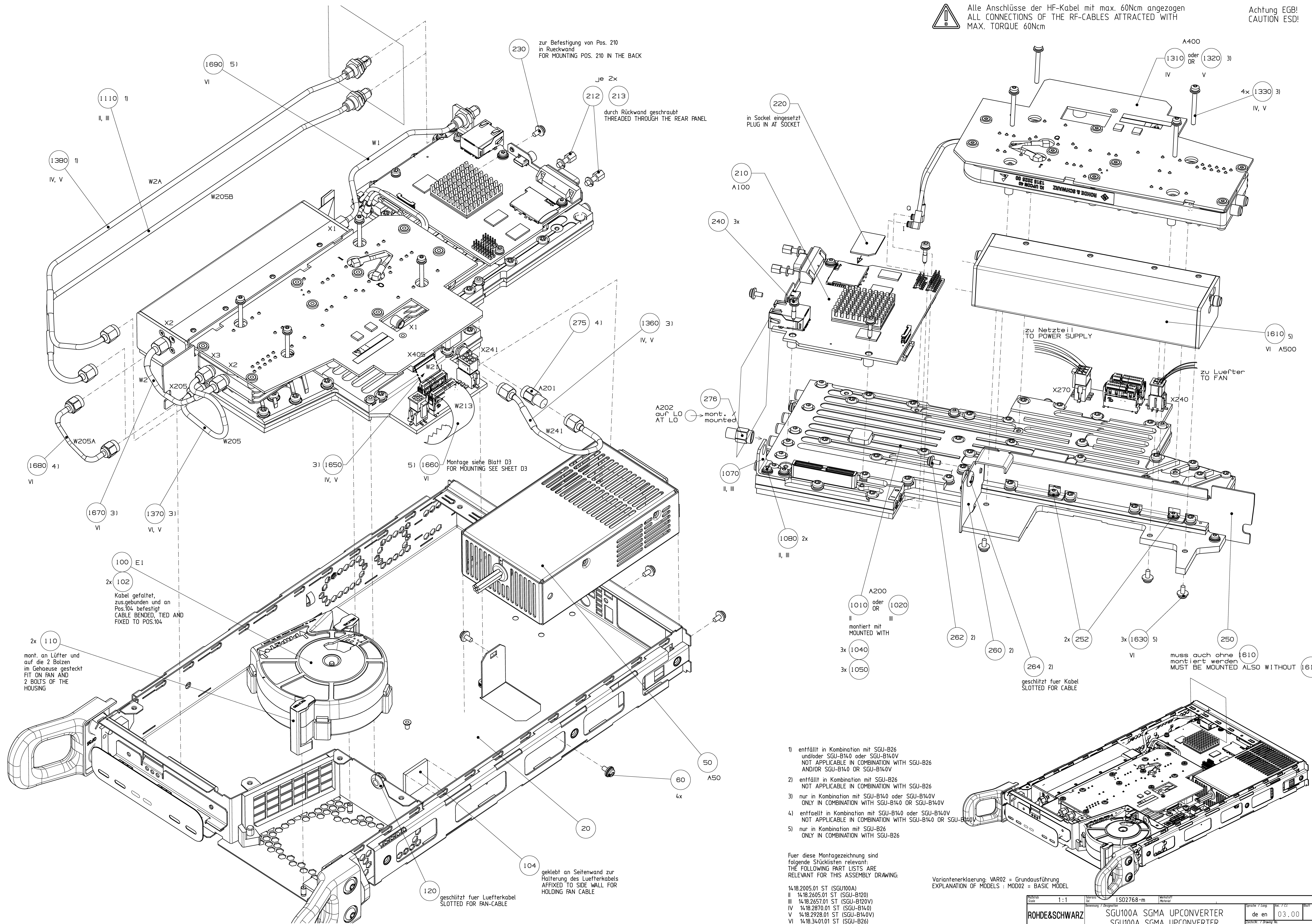

- 1) entfällt in Kombination mit SGU-B26 und/oder SGU-B140 oder SGU-B140V
 NOT APPLICABLE IN COMBINATION WITH SGU-B26 AND/OR SGU-B140 OR SGU-B140V
- 2) entfällt in Kombination mit SGU-B26
 NOT APPLICABLE IN COMBINATION WITH SGU-B26
- 3) nur in Kombination mit SGU-B140 oder SGU-B140V
 ONLY IN COMBINATION WITH SGU-B140 OR SGU-B140V
- 4) entfällt in Kombination mit SGU-B140 oder SGU-B140V
 NOT APPLICABLE IN COMBINATION WITH SGU-B140 OR SGU-B140V
- 5) nur in Kombination mit SGU-B26
 ONLY IN COMBINATION WITH SGU-B26

Fuer diese Montagezeichnung sind folgende Stücklisten relevant:
 THE FOLLOWING PART LISTS ARE RELEVANT FOR THIS ASSEMBLY DRAWING:

- 1) 14.18.2005.01 ST (SGU100A)
- II 14.18.2605.01 ST (SGU-B120)
- III 14.18.2657.01 ST (SGU-B120V)
- IV 14.18.2870.01 ST (SGU-B140)
- V 14.18.2928.01 ST (SGU-B140V)
- VI 14.18.3401.01 ST (SGU-B26)

Variantenerklärung: VAR02 = Grundauführung
 EXPLANATION OF MODELS: MOD02 = BASIC MODEL

Maßstab Scale	1:1	Maßstab Scale	IS02768-m	Werkstoff Material	
Hersteller Manufacturer	ROHDE&SCHWARZ	Produkt Product	SGU100A SGMA UPCONVERTER	Zeichnungs-Nr. Drawing No.	de en 03.00 1
Teil-Nr. Part No.	SGU100A	Revisions-Nr. Revision	2014-06-23	Gezeichnet Drawn	HI
		Geprüft Checked	TGPK	Freigegeben Released	HI
		Datum Date	14.18.2005.01	Blatt / Page	1 / 1

Für dieses Dokument behalten wir uns alle Rechte vor.
 For this document all rights are reserved.

Projektions-
methode
Projection
Method

(NX)

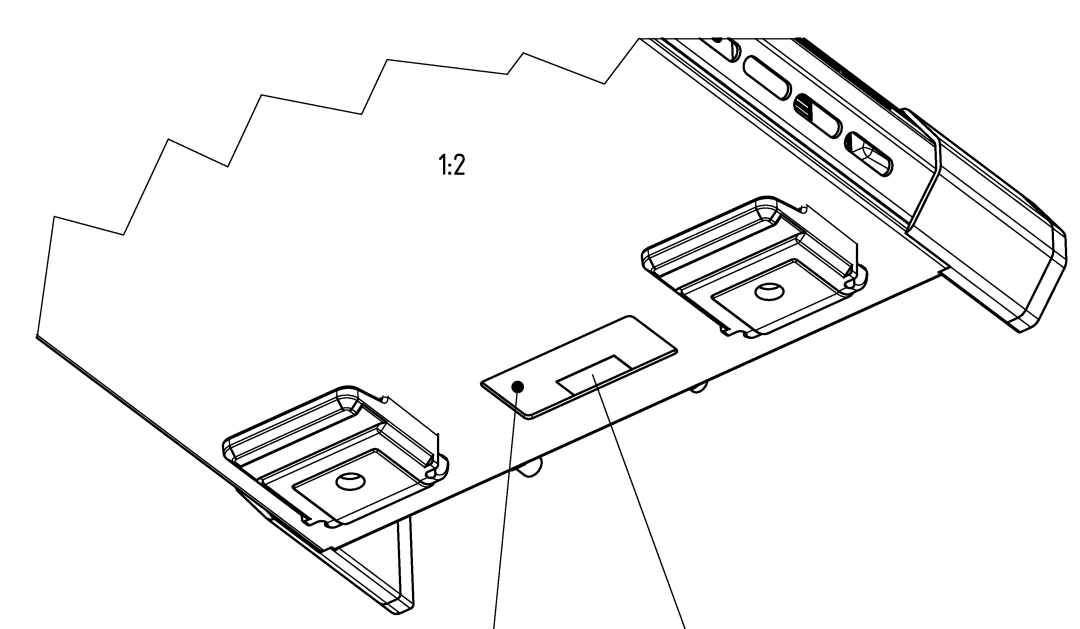
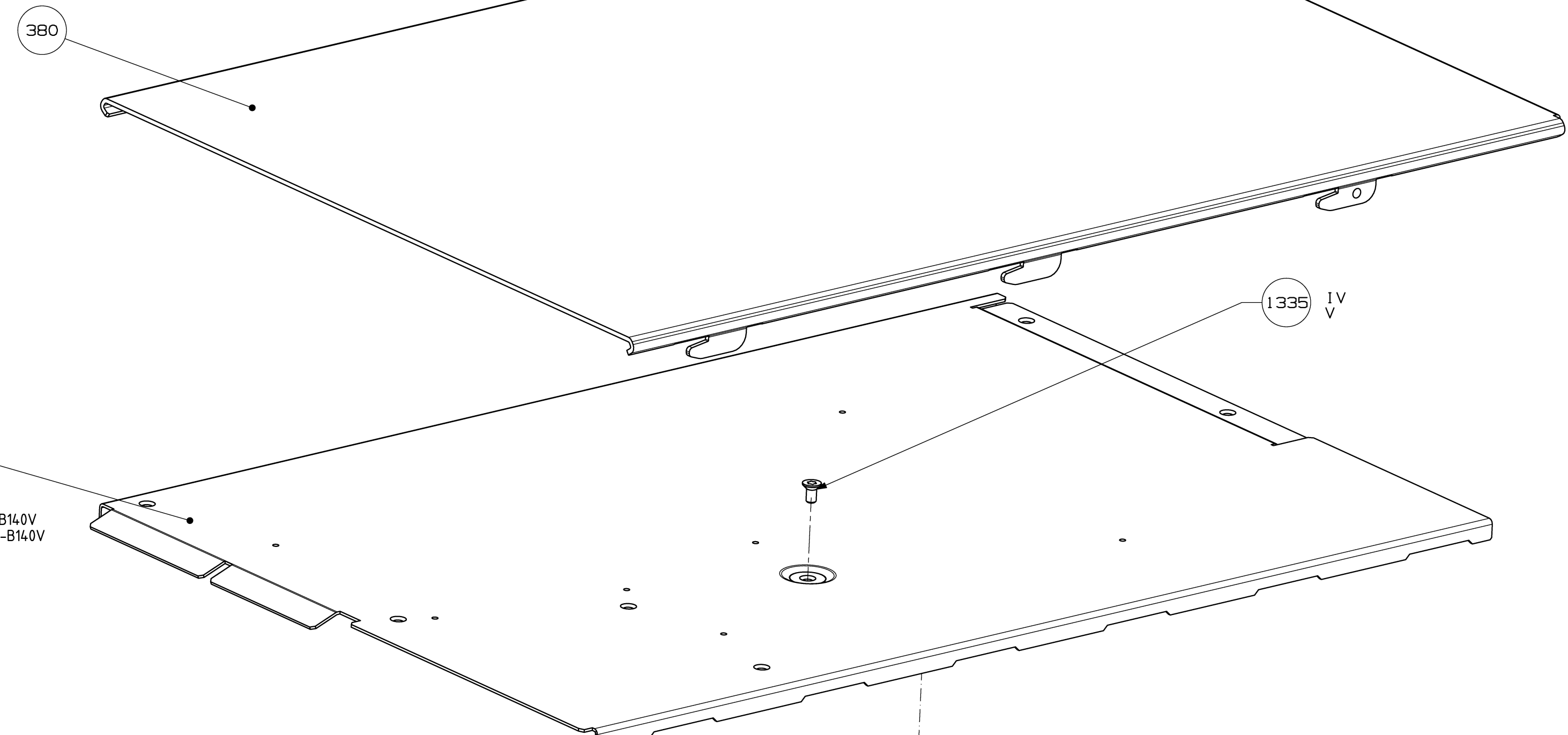

hier MAC-ADR-Schild (Teil von SAP-Schild), aufgeklebt
HERE MAC-ADR-LABEL (PART OF SAP-LABEL) GLUED

zwischen die 4 Fangwarzen auf Pos. (350) geklebt
GLUED, BETWEEN THE CAPTIVE PADS ON POS. (350)

152 kontaktiert in (150) und (210)
W300

154 zum Fixieren der Flachleitung (52)

das Barcode-/SAP-Schild auf die Rückwand kleben, senkrecht, von rechts lesbar, neben Rückwandfuss.
HERE GLUEING SAP-LABEL ON THE BACK WALL, VERTICAL AND READABLE FROM THE RIGHT

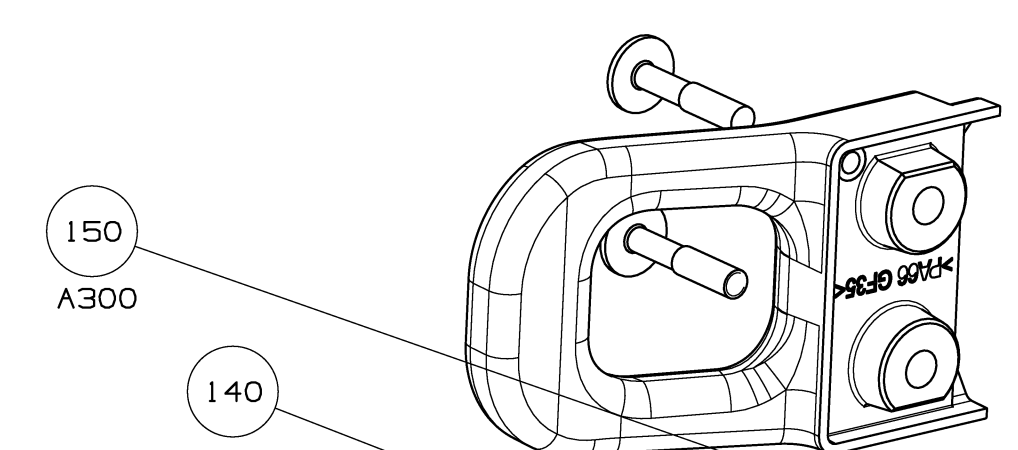

720 2x

480 2x

730 2x

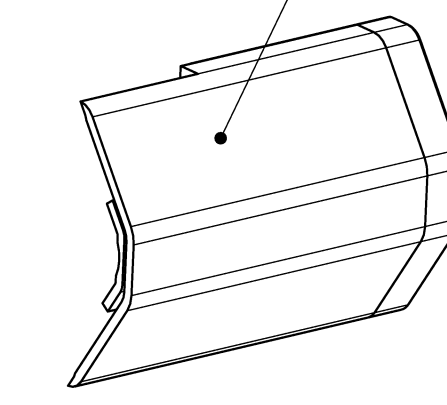

450 2x

Schild geklebt
LABEL GLUED

1022 II
oder OR
1024 III
oder OR
1340 IV
oder OR
1342 V

130

350

360 4x

170 2x

180 4x

12

Für dieses Dokument behalten wir uns alle Rechte vor
For this document all rights are reserved

Projektionsmethode
Projection Method

Für diese Montagezeichnung sind folgende Stücklisten relevant:
THE FOLLOWING PART LISTS ARE RELEVANT FOR THIS ASSEMBLY DRAWING:

14.18.2005.01 ST (SGU100A)
II 14.18.2605.01 ST (SGU-B120)
III 14.18.2657.01 ST (SGU-B120V)
IV 14.18.2870.01 ST (SGU-B140)
V 14.18.2928.01 ST (SGU-B140V)
VI 14.18.3401.01 ST (SGU-B26)

Maßstab Scale	1:1	Zeichnung / Drawing	1S02768-m	Werkstoff / Material		Spalte / Col.	Maß / Len.	Blatt / Sh.
Hersteller Manufacturer	ROHDE&SCHWARZ	Bezeichnung / Description	SGU100A SGMA UPCONVERTER	Version / Ver.	de en	04.00	2	
Teilnummer Part No.	SGU100A	Datum Date	2014-09-22	Abw. / Dep.	TGPK	Hersteller Manufacturer	HI	14.18.2005.01 D

Für dieses Dokument behalten wir uns alle Rechte vor
For this document all rights are reserved

(NX)

Projektions-
methode
Projection
Method



Alle Anschlüsse der HF-Kabel mit max. 60Ncm angezogen
ALL CONNECTIONS OF THE RF-CABLES ATTRACTED WITH
MAX. TORQUE 60Ncm

Achtung EGB
CAUTION ESD

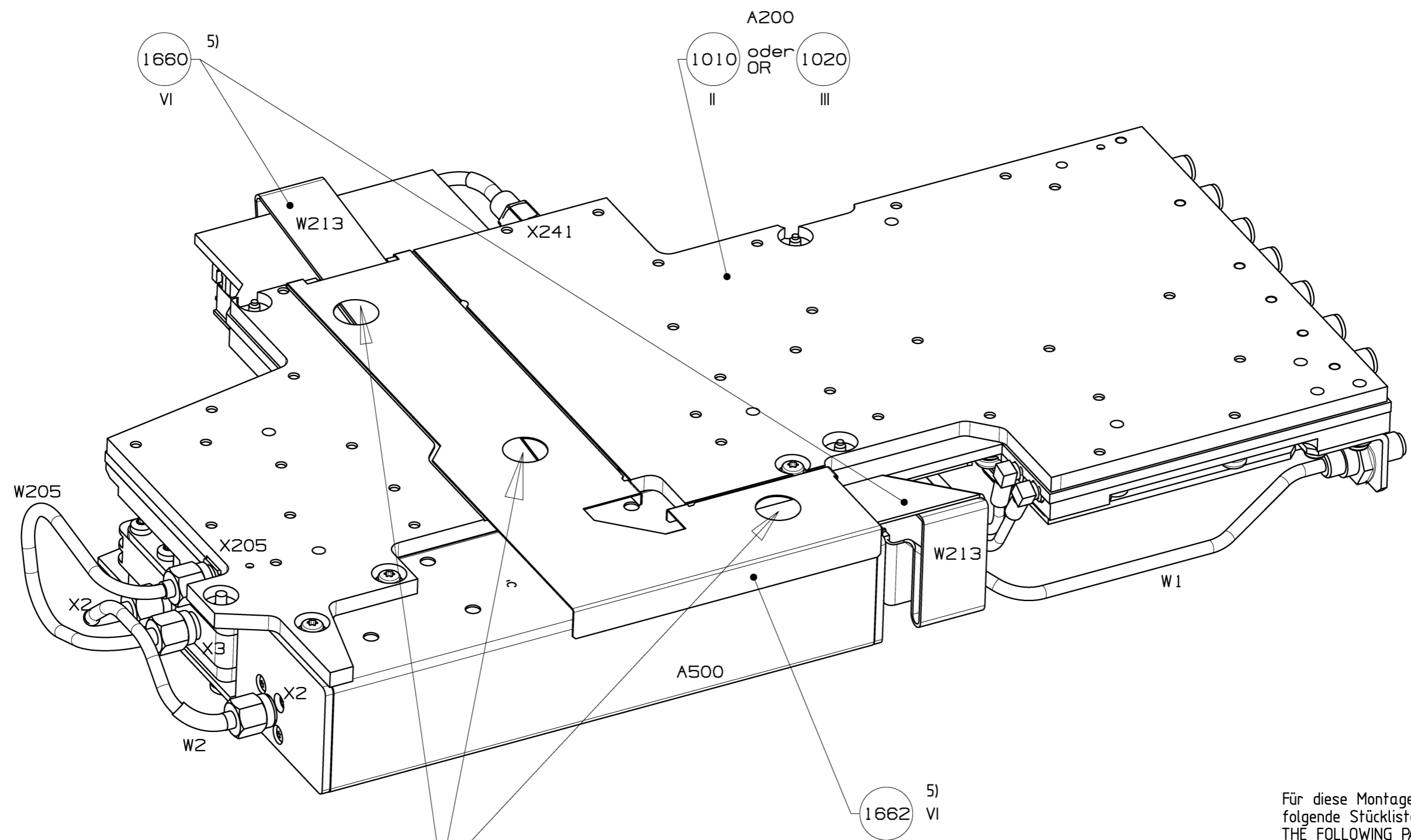

W213 gefaltet und in flacher Nut der Haube, unten verlegt und mit 1662 fixiert.
Hier darauf achten, daß das Flachbandkabel in den Vertiefungen liegt
HERE MAKE SURE THAT THE CABLE IS IN THE DEEPENING

zur Fixierung des Flachbandkabels in der Vertiefung der Haube
FOR FIXING THE FLAT RIBBON CABLE IN THE DEEPENING OF THE HOOD

Für diese Montagezeichnung sind folgende Stücklisten relevant:
THE FOLLOWING PART LISTS ARE RELEVANT FOR THIS ASSEMBLY DRAWING:

- 14.18.2005.01 ST (SGU100A)
- II 14.18.2605.01 ST (SGU-B120)
- III 14.18.2657.01 ST (SGU-B120V)
- IV 14.18.2870.01 ST (SGU-B140)
- V 14.18.2928.01 ST (SGU-B140V)
- VI 14.18.3401.01 ST (SGU-B26)

Maßstab Scale	1:1	Toleranz Tol.	ISO2768-m	Werkstoff Material	
Benennung / Designation		SGU100A SGMA UPCONVERTER		Sprache / Lang.	de en
ROHDE&SCHWARZ		SGU100A SGMA UPCONVERTER		Ael. / C.I.	02.00
Datum Date		2013-04-18		Blatt / Sh.	
SGU100A		Abteilung Dept.		3	
		1GPK		Name Name	
		Si/Hi		Zeichn.Nr. / Drawing No.	
				1418.2005.01	
				D	

SGU100A +Opt.

Front Panel

Rear Panel

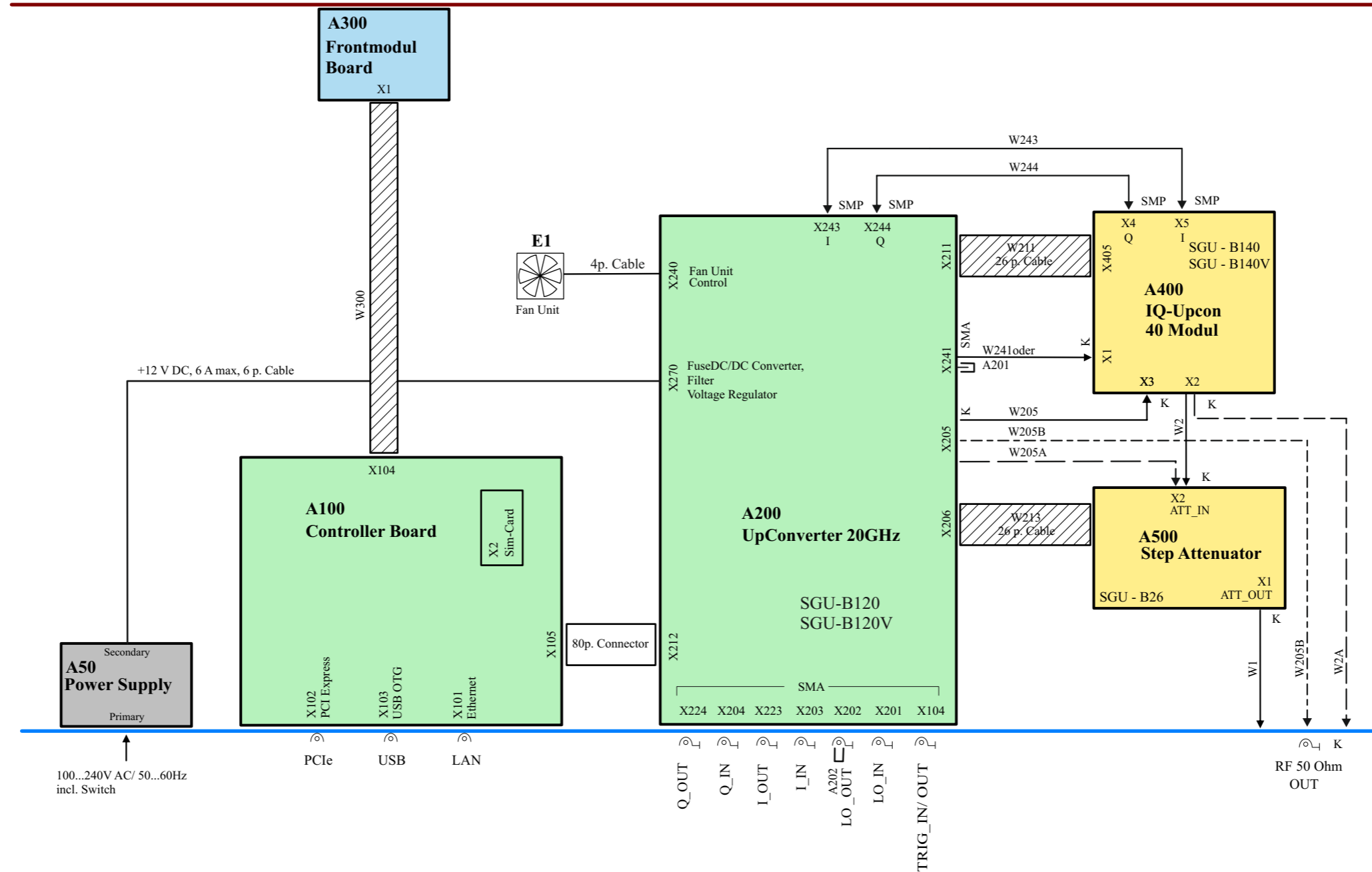

Für diese Unterlage behalten wir uns alle Rechte vor.

D

ISO-Projektion
Methode E



ROHDE&SCHWARZ		Benennung: Designation: SGU100A SGMA UPCONVERTER		Sprache: / Lang.: de		Aei: / C.I.: 05.00		Blatt: / Sh.: 1 -	
Typ: SGU100A		Datum: 23.06.2014		Abteilung: 1GPK		Name: Hi/JR		Zeichn. Nr.: / Drawing Nr.:	
1. Z.: 1418.2005.01		used in:						1418.2005.01 FS	

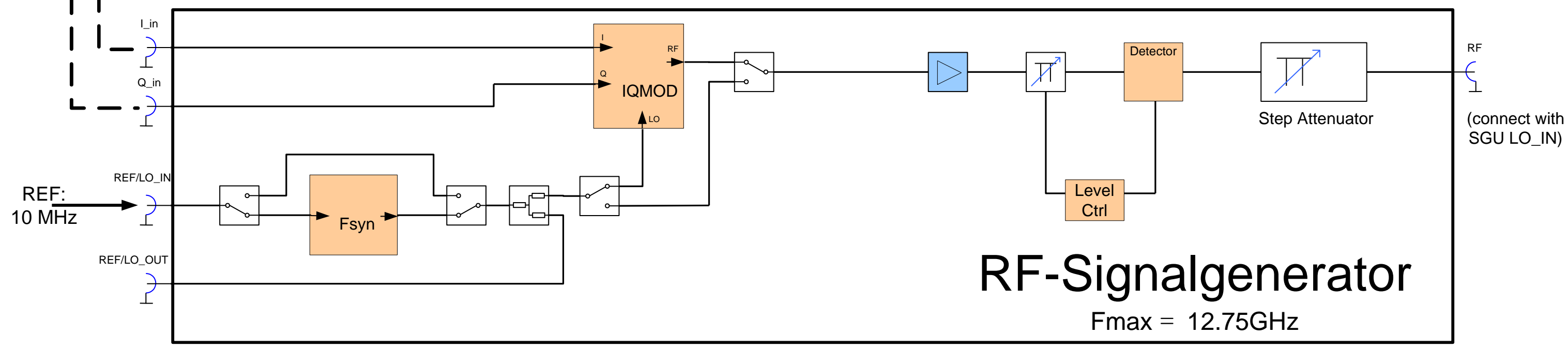
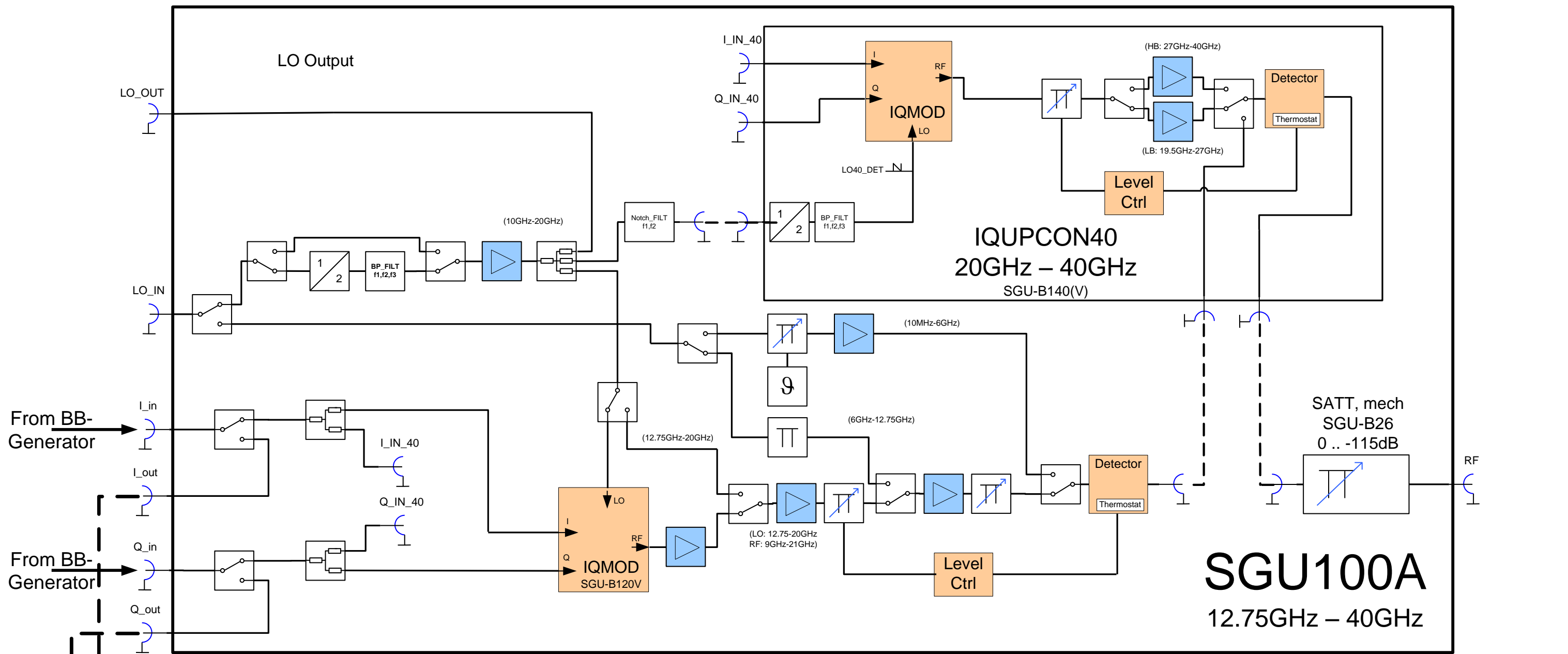

Index

Adjustments	
External	42
Internal	42
Functional Description	
Controller Board.....	45
Doubler Board	48
Power Supply Module	45
Step Attenuator	49
Upconverter Mainboard	46
Installing	
Controller board.....	88
EMC Panel	75
Frontmodulboard	81
IQ-Upcon 40 Module.....	92
Power Supply	77
Push-Button Board	81
RF-Upconverter	85
Step Attenuator	96
Instrument Faults	59
Internal Self Test	42
Keyboard and LED Test	54
Measuring Equipment and Accessories	51
Module Replacement	71
Modules overview	53, 72
Motherboard	45
Output impedance	
Test assembly.....	10
Overview of the Modules.....	72
Performance Test.....	7
Power Cables	100
Power Supply Module	45
Pulse modulation	
Test procedure.....	30, 32
Removing	
Controller Board.....	88
EMC Panel	75
Front Unit.....	78, 79
Frontmodulboard	80
Power Supply	76
Push-Button Board	80
RF-Upconverter	82
Repair	44
Replacing	
Controller Board	88
EMC Panel	75
Fan.....	90
Front Unit.....	78
Frontmodulboard	80
IQ-Upcon 40 Module.....	91
Power Supply	76
RF-Upconverter	82
SIM Card	89
Spare Parts.....	100
Switch-On Problems	51, 52, 54
Test assembly	
Output impedance	10
Test Equipment	7
Test Frequencies	13
Test Levels.....	13
Test procedure	
Pulse modulation	30, 32
Troubleshooting	50
Doubler Board Option	68
Internal Adjustments	58
Internal Selftest.....	57
Step Attenuator	67
Switch-On Problems	52, 54
Upconverter Mainboard	64
USBCable Test	55